

INSTALLATION INSTRUCTIONS

Amarr Residential Steel Garage Doors

Entrematic manufactures & distributes garage doors under several brand names and trademarks, such as: Amarr®, Heritage™, Classica®, Stratford®, Oak Summit® and other consumer brands and product names.

Table of Contents

- Page 1 - Table of Contents
- Page 2 - Safety Information and Warnings
- Page 3 - Safety Information and Warnings (continued)
- Page 4 - Parts Index and Quantities
- Page 5 - Parts Index and Quantities (continued)
- Page 6 - Preparing the Jamb and Spring Pad / Parts Required
- Page 7 - Installing Hardware on the Sections
- Page 8 - Stacking Sections in the Opening / Installing Vertical Track
- Page 9 - Stacking Sections (continued)
- Page 10 - Stacking the Top Section / Installing Struts
- Page 11 - Garage Door Opener Bracket - *Required for Triple Layer Doors*
- Page 12 - Strut Information and installation
- Page 13 - Installing the Horizontal Track and Completing the Installation
- Page 14 - Track Hanger Installation (track parallel to joists)
- Page 15 - Track Hanger Installation (track perpendicular to joists)
- Page 16 - Torsion Spring Installation
- Page 17 - Slide Lock Installation (not to be used with electric opener)
- Page 18 - Perimeter Seal / Stop Molding
- Page 19 - Low Head Room Torsion to the Front Installation
- Page 20 - Low Head Room Torsion to the Rear Installation
- Page 21 - Extension Spring Installation - *Standard Lift*
- Page 22 - Extension Spring Installation - *Low Head Room*



ENTRE//MATIC

165 Carriage Court, Winston Salem, NC 27105
For replacement documents, parts, or questions about installation, call 1-800-503- DOOR
Hours of Operation:
Monday - Friday 7am to 7pm Central Time
Saturday 8am to 4:30pm Central Time
www.amarr.com

Installer: After installation is complete, attach all warning labels, and tags where indicated and place this manual near the door.

Date of installation:

Installed by:

Notes:

READ THE ENTIRE INSTRUCTIONS BEFORE USING THIS PRODUCT. FAILURE TO FOLLOW THE INSTRUCTIONS AND SAFETY PRECAUTIONS IN THIS DOCUMENT CAN RESULT IN SERIOUS INJURY OR DEATH. KEEP THE INSTRUCTIONS IN A SAFE LOCATION FOR FUTURE REFERENCE. ALSO READ THE OWNERS MANUAL (PROVIDED SEPARATELY).

Installation Instructions are available at no charge from Amarr, call toll free 1.800.503.DOOR, email:ask@amarr.com, or online at www.amarr.com.



Table of Contents

Overview of Safety Guidelines and Your Responsibilities:

1. Overhead garage doors are large, heavy objects that move with the help of springs under high tension and electric motors. Since moving objects, springs under tension, and electric motors can cause injuries, your safety and the safety of others depend on you thoroughly reading and understanding these instructions and the owners manual (provided separately). If you have questions or do not understand the information presented, call 1.800.503.DOOR.

2. Most garage door incidents are caused by failure to observe basic safety rules or precautions. An incident can often be avoided by recognizing potentially hazardous situation before an incident occurs. A person must be alert to potential hazards. This person should also have the necessary training, skills and tools to install the door properly.

3. This is the safety alert symbol. It is used to alert you to potential personal injury hazards. The meaning of this safety alert symbol is as follows: **Attention! Become Alert! Your Safety may be at Risk.** The message that appears under the warning explains the hazard and can be either written or pictorially presented.



4. Obey all safety messages that follow the Safety Alert symbol to avoid possible personal injury or death. The hazards are identified by the "Safety Alert Symbol" and followed by a "signal word" such as "WARNING" or "CAUTION". For your convenience, the signal words and definitions are provided below:

- **WARNING:** Indicates a hazardous situation which, if not avoided, could result in death or serious bodily injury.
- **CAUTION:** Indicates a hazardous situation which, if not avoided, could result in minor or moderate bodily injury.
- **NOTICE:** Indicates a situation that could result in equipment related damage.
- **Safety Symbols** – The following safety symbols appear throughout this manual to alert you to important safety hazards and precautions to prevent injury.



WEAR SAFETY GLASSES



READ THIS MANUAL



WEAR HARD HAT



WEAR GLOVES



PROHIBITION



OVERHEAD CRUSH HAZARD

5. Every possible circumstance that might involve a potential hazard cannot be anticipated. The warnings in this publication and on the product are, therefore, not all inclusive. If a tool, procedure, work method or operating technique that is not specifically recommended by Entrematic is used, you are responsible that it is safe for you and for others. You are responsible that the product will not be damaged or be made unsafe by the operation, lubrication, maintenance or repair procedures that you choose.

General Safety Guidelines:

- **DO NOT** permit children to operate the garage door or door controls. Severe or fatal injury could result should a child become entrapped between the door and the floor.
- **DO NOT** attempt to adjust, repair or alter any part of the garage door, especially to springs, spring brackets, bottom corner brackets, fasteners, counterbalance lift cables or supports. Installation and repair work **MUST** be performed by a trained garage door technician.
- **RED** fasteners must be used where required. These fasteners hold parts which are under extreme tension. **RED** fasteners are not to be loosened or removed.
- **DO NOT** stand or walk under a moving garage door. Keep door fully in view and free of obstructions when operating.
- **DO NOT** place fingers or hands into open section joints or track when garage door is moving.
- **REMOVE** pull down ropes and disable locks on electrically operated garage doors.
- **ALWAYS** wear work gloves and safety glasses during installation.
- **INSPECT** doors and hardware monthly for worn and or broken parts.
- **TEST** electric garage door opener's safety features monthly, according to manufacturer's instructions.
- **DO NOT** hang tools or materials from horizontal tracks.
- **DO NOT** install the garage door on windy days. Garage door could fall during the installation causing severe or fatal injury.
- This garage door **MAY NOT** meet the building code wind load requirements in your area. Contact your local building official for wind load code requirements and building permit information.

- **WARNING LABELS** are important parts of the garage door(s).
- Place warning labels as indicated to the right, so that they are not obstructed and can be easily read.
- **DO NOT** remove, cover or paint over the labels. Users should inspect labels periodically for legibility and should order (free of charge) replacement labels from Amarr, as needed. Please call toll free 1.800.503.DOOR or email ask@amarr.com.

NOTICE The following four warning labels should be present on or around garage door assemblies:

1. Spring Warning Label, attached to the spring assembly;
2. General Warning Label, attached to the back of the garage door panel;
3. Warning Label for Garage Door Opener (provided separately with opener) attached to the wall in the vicinity of the wall control button, and;
4. Bottom Bracket Tension Warning Label, attached above the garage door's bottom brackets.

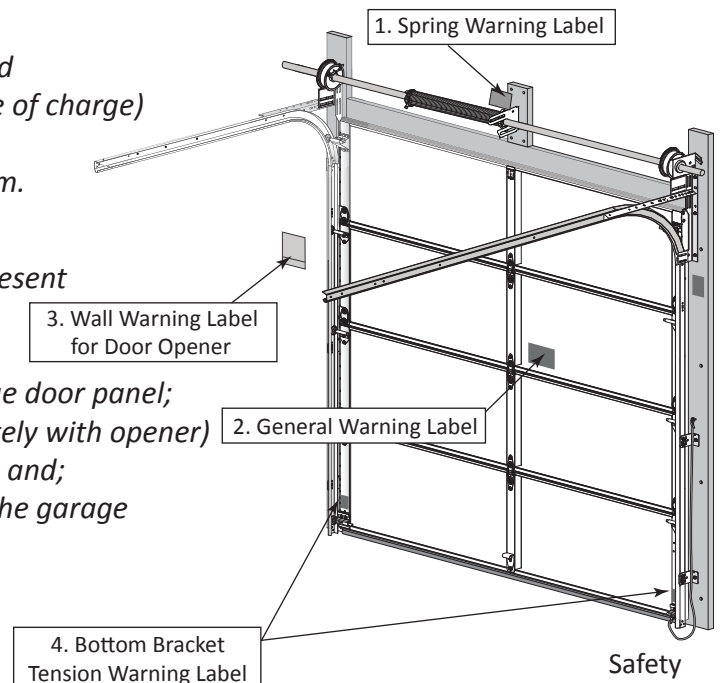

Safety
Information

3

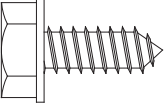
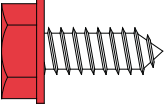
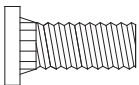
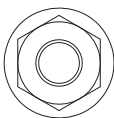
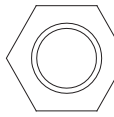
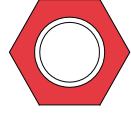
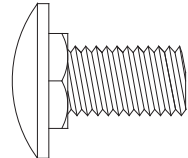
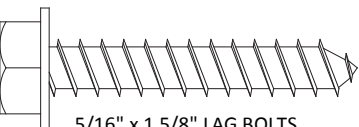
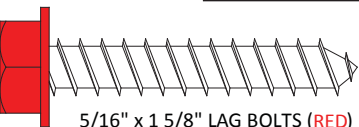
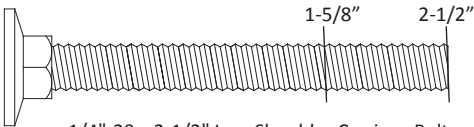
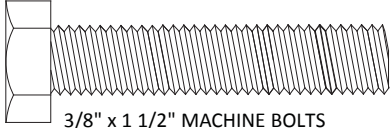
Fasteners (Actual Size) Minimum Quantity Required		3 Section Garage Door			4 Section Garage Door				5 Section Garage Door				
		Center Stiles	1	2	3	1	2	3	4	1	2	3	4
	1/4 x 5/8 UNIVERSAL SCREWS	Center Stiles	1	2	3	1	2	3	4	1	2	3	4
		# Fasteners	34	42	70	46	58	80	130	58	74	100	154
	1/4 x 3/4 UNIVERSAL SCREWS (RED - TEK)		4			4				4			
	1/4" x 5/8" TRACK SPLICE BOLTS		8			8				8			
	1/4" x 20 SERR. WASHER HEAD NUTS		10			10				10			
	3/8" - 16 Hex Nut		6			6				6			
	3/8" - 16 RED Hex Nut		2			2				2			
	3/8" x 3/4" LSC BOLTS		2			2				2			
	5/16" x 1 5/8" LAG BOLTS		12			12				12			
	5/16" x 1 5/8" LAG BOLTS (RED)		2			2				2			
	1/4"-20 x 2-1/2" Low Shoulder Carriage Bolt		2			2				2			
	1/4"-20 x 1-5/8" (for 1-3/8" thick doors) Low Shoulder Carriage Bolt												
	3/8" x 1 1/2" MACHINE BOLTS		2			2				2			

Required Parts

4

NOTICE

A Windload specific drawing will accompany your garage door showing where the extra parts are located.

Minimum Hardware Required Up to 8' Tall (Not Actual Size)			
(★ Hardware for Torsion Spring Only)	3 Section Garage Doors	4 Section Garage Doors	5 Section Garage Doors
End Hinge (Right Shown)	Two Left & Two Right	Three Left & Three Right	Four Left & Four Right
Rollers (Yours may appear different)	8	10	12
Jamb Brackets	4	4	4
Center Bearing Plate	1	1	1
Torsion Cables	One Pair	One Pair	One Pair
End Bearing Plate	One Left & One Right	One Left & One Right	One Left & One Right
Cable Drums	One Left & One Right	One Left & One Right	One Left & One Right
Top Fixture	2	2	2
Lift Handle	Minimum 2	Minimum 2	Minimum 2
Roller Carriers (numbered)	4	6	8
Bottom Fixture (to be assembled)	One Left & One Right	One Left & One Right	One Left & One Right
Center Hinge	Minimum 2	Minimum 3	Minimum 4
Stile Stiffener	Minimum 1	Minimum 1	Minimum 1
Hinge Hole Plug	Minimum 1	Minimum 1	Minimum 1
Nylon Bearing	1	1	1
Flag Bracket	One Left & One Right	One Left & One Right	One Left & One Right
End Stile Slide Lock	Minimum 1	Minimum 1	Minimum 1
Torsion Spring	Minimum 1	Minimum 1	Minimum 1
Lift Handle / Step Plate Tube Spacers <small>Yellow Red Black</small>	Minimum 2 Each	Minimum 2 Each	Minimum 2 Each

Additional Hardware Required
For Torsion Spring Low Head Room Front Mount
(Not Actual Size)

	Minimum Required
Low Head Room Top Fixture	2

Additional Hardware Required
For Torsion Spring Low Head Room Rear Mount
(Not Actual Size)

	Minimum Required
Low Head Room Top Fixture	2
End Bearing Plate	2
Outside Hook-Up Bottom Fixture	1 Left & 1 Right

Additional Hardware Required
For Standard Lift, Extension Spring Doors
(Not Actual Size)

* Extension Spring Minimum (2) Required These Parts Replace ★ Items Minimum Required

Extension Spring Parts Bag Including: (4) Pulleys (2) Sheave Forks (2) Cable Adjustment Clips (2) "S" Hooks (2) Eye Bolts (2) Lift / (2) Safety Cables (4) 5/16 x 18 RED Hex Nuts (4) 3/8 x 16 RED Hex Nuts	1 Bag
--	-------

Additional Hardware Required
For Low Head Room, Extension Spring Doors
(Not Actual Size)

* Extension Spring Minimum (2) Required These Parts Replace ★ Items Minimum Required

Low Head Room Top Fixture	2
Outside Hook-Up Bottom Fixture	1 Left & 1 Right
Extension Spring Parts Bag Including: (4) Pulleys (2) Sheave Forks (2) Cable Adjustment Clips (2) "S" Hooks (2) Eye Bolts (2) Lift / (2) Safety Cables (4) 5/16 x 18 RED Hex Nuts (4) 3/8 x 16 RED Hex Nuts	1 Bag

NOTICE

Your door kit may contain more parts than shown here. These are the minimum parts required for most single car garage door installations.

Required Parts

5

Tools Required for Installation:

- Six Foot (6') Step Ladder
- Level 24" or 48"
- Claw Hammer
- Lock Grip Pliers or C clamps
- Socket Wrench
- Sockets: 3/8", 7/16" and 9/16"
- Wrenches: 3/8", 7/16" and 9/16"
- Electric Drill
- Drill Bits: 3/32", 3/16", 1/4", and 3/8"
- Chalk
- Tape Measure
- Saw Horses - with padded top surfaces
 - (2) Needed for garage doors up to 9' wide
 - (3) Needed for garage doors wider than 9'

Not Included/Purchase Separately:

- Perimeter Seal / Aluminum Brads
- Operator Bracket (if using operator)
- Track Hanger Angle / Additional Lag Screws
- Winding Bars (for Torsion Spring / Purchase from Amarr)
- 16-Penny Nails

Figure 2

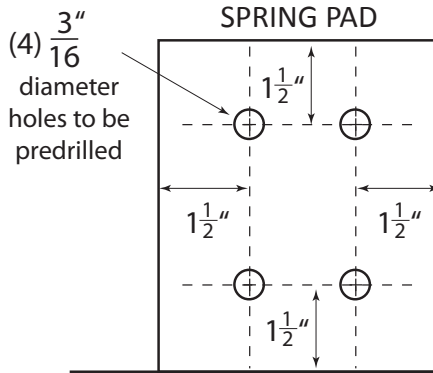

WARNING

WARNING - Strike Hazard

The jamb and spring pad **MUST** be securely anchored to the wall. Failure to secure the jamb or spring pad could result in death or serious bodily injury. Attach **ONLY** to #2 Southern Yellow Pine (or better). **DO NOT** use nails to secure the track or spring pad.

*See Dasma TDS-161 (www.dasma.com)

SPRING PAD REQUIREMENTS:

- *Minimum 2"x 6" Southern Yellow Pine, Grade #2 or better.
- *Spring Pad should span from the header to height of ceiling .
- *Pre-drill (4) 3/16" diameter holes, no closer than 1-1/2" from any edge.
- *Secure Spring Pad with (4) 5/16"x 4" lag screws (not included).
- *DO NOT attach directly to drywall or sheetrock.

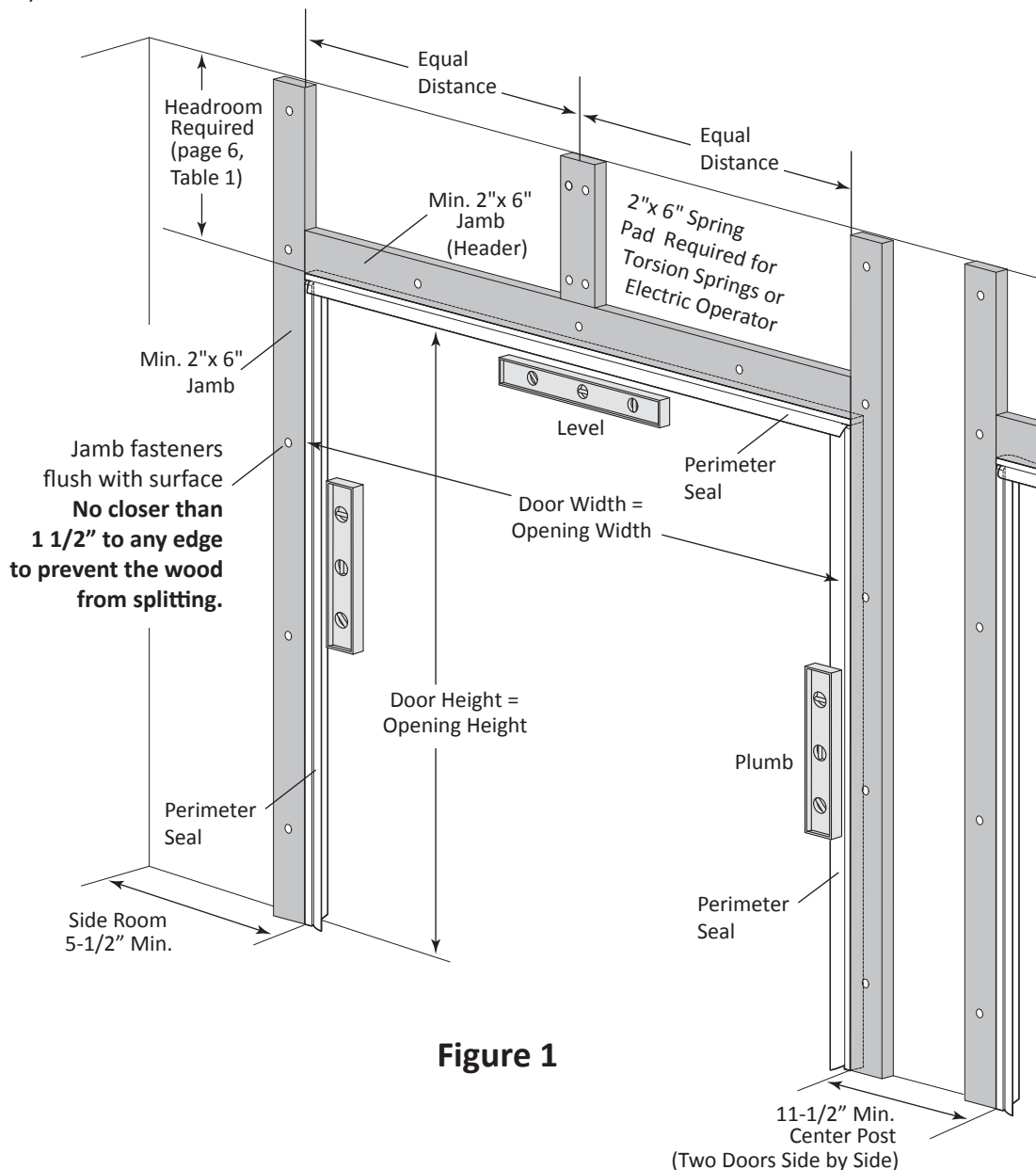

Figure 1

Step 1: Framing the Opening

The garage door (rough) opening should be approximately the same size as the door (Figure 1, page 6). The opening must be framed with 2" x 6" minimum, wood jambs. Torsion Spring and Opener applications require 2" x 6" minimum Spring Anchor Pads (see Figure 2, page 6). The jambs must be plumb and the header level for a square opening. The jambs should extend to the same height as the headroom required (Table 1). All jamb fasteners should be flush with the jambs and securely anchored to the wall.

Note: Jamb and Spring Pad installation is typically performed by the builder (carpenter) of the home at the time of home construction.

Step 2: Perimeter Seal Installation

Perimeter Seal is to be purchased separately. It is not supplied with your door, see Page 18 for details.

Step 3: Section Selection

Check the section height chart (Table 2) to ensure proper quantity of sections. The bottom section has a rubber weather seal on the bottom. The inside of the sections have pre-drilled holes for most fasteners.

Note: If struts are supplied with your door, refer to page 12 for proper placement, and Page 10, Step 22 (A or B) for strut installation instructions.

Step 4: Safety Bottom Bracket Installation

Locate the Safety Bottom Bracket assembly (Figure 3). Separate all four parts by snapping apart (Figure 4). Place the bottom section face down on a sturdy pair of padded saw horses (Figure 5). Attach the left Bottom Bracket Base to the bottom of the left end stile (Figure 5A) aligning with holes #20 & #23 (#15 & #18 on Triple Layer doors). Fasten the base with (2) 1/4" x 5/8" RED Universal Screws. Align the Bottom Bracket Roller Carrier with the matching holes in the base and attach with (2) 1/4" x 5/8" Universal Screws. Insert the Roller into the Bottom Bracket Roller Carrier (Figure 5G). Repeat this procedure for the right end stile.

Note: Holes in the stiles may not line up with all fixtures, handles, and locks. Use a 3/32" drill bit to start pilot holes for fasteners where pre-drilled holes are not provided. Not all holes will be used.

Step 5: Lift Cable Installation

Secure the lift cable to the bottom bracket by hooking the looped end of the cable over the lifting stud (figure 5B). If two sets of cables are supplied, use the longer cables as lift cables.

Step 6: Roller Carrier Installation

Roller carriers have a number stamped on them for identification and their placement on the door is important (Figure 5C). All roller carriers are attached to the end stiles with (2) 1/4" x 5/8" Universal Screws, using holes #2 & #6 (#4 & #8 on Triple Layer doors). Insert rollers as shown (Figure 5C). Start with Roller Carrier #1 for the bottom section, then using #2, #3, #4 as required.

Note: (3) Section tall doors start with a #2 Roller Carrier.

Step 7: Center Hinge Installation

Locate the Center Hinges, rotate and insert the hinge(s) into the hinge pocket(s) (Figure 5D). All Center Hinges are attached with (2) 1/4 x 5/8" Universal Screws using holes A & C (#4 & #6 on Triple Layer doors Figure 5D*).

Note: The words "THIS SIDE OUT" must be visible. The actual hinge point or barrel of the hinge, must be inside of the hinge pocket.

Step 8: Step Plate / Lift Handle Installation

For Single & Double Layer doors, drill two (2) 1/4" holes straight through the Center Stile and face of the door, using pre-punched holes U & W on the stiles as a template on the bottom end of the center stile (Figure 5E).

For Triple Layer Doors, drill two (2) 1/4" holes straight through the Center Stile and face of the door, using the two dimples near the bottom of the section as a template. Then drill (2) 3/8" holes through the inside skin only (to insert the Tube Spacer).

Install the Step Plate / Tube Spacers / Lift Handle (outside & inside) using (2) 1/4" - 20 x 2-1/2" Carriage Bolts and 1/4"-20 Nuts (bolt heads should be on the outside) (on Triple Layer doors refer to Figure 5F*). Do not over-tighten, you could crush the section and the tube spacers.

Note: For all Single & Double Layer doors use Yellow Tube Spacers.

For 1-3/8" thick, Triple Layer doors use Black Tube Spacers. For 2" thick, Triple Layer doors use Red Tube Spacers.

Table 1 - Headroom Chart

Type of Spring	Track Radius	Min. Headroom Required	Min. Headroom Req'd w/ Opener
Extension	12"	12"	15"
Extension	15"	15"	18"
Torsion	12"	12"	15"
Torsion	15"	15"	18"

Table 2 - Door Height Configuration

Door Height	Section Height & Quantity (For doors over 8' tall, contact Amarr Garage Doors)			
	18"	21"	28"	32"
6'-0"	4			
6'-2"	1		And 2	
6'-3"	3	1		
6'-5"		1	And 2	
6'-6"	2	2		
6'-9"	1	3		
6'-9"		1	And 1	1
6'-10"	1			2
7'-0"		4	Or 3	
7'-1"		1	And 2	
7'-4"			2	1
7'-6"	5			
7'-8"			1	2
7'-9"	4	1		
8'-0"	3	2	Or 3	

Note: Marked L & R For Right or Left Side Mount

Bottom Bracket Roller Carrier

Bottom Bracket Base

Figure 3

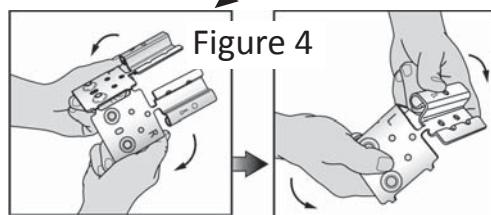
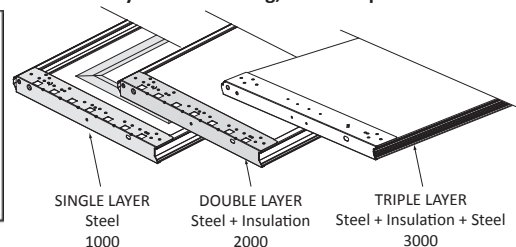

Figure 4

Note: It is important to know which model you are installing, see examples below.



Note: Your garage door may appear slightly different, but installation steps are the same.

Figure 5

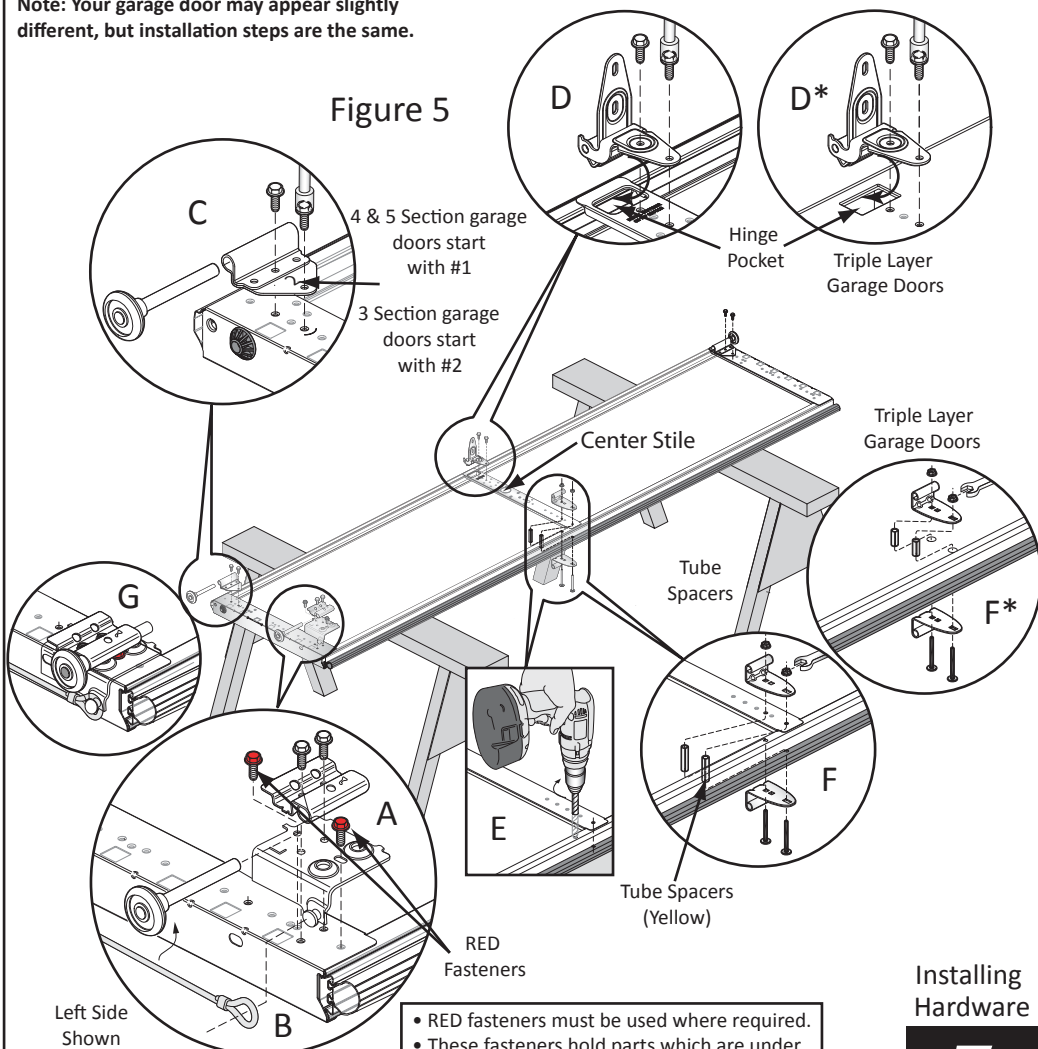

Left Side Shown

- RED fasteners must be used where required.
- These fasteners hold parts which are under extreme tension.
- RED fasteners are not to be loosened or removed.

WARNING

Installing Hardware

7

Step 9: Stacking the Bottom Section in the Opening
Place the bottom section (with hardware installed) in the opening against the Perimeter Seal and centered from side to side (Figure 6). Place a level on the top of the section (Figure 6A). If necessary, use a piece of wood as a shim under the low side to make the section level (Figure 6B).

Step 10: Securing the Section in the Opening
Temporarily secure the section in the opening by driving a 16-penny nail into the jamb at each end of the section and carefully bend it over the edge of the section to secure it in place (Figure 6C). Make sure the section is securely held in place.

Steps 11-15: Track Assembly and Attachment

⚠ WARNING High Spring Tension, Strike Hazard
The track and spring pad are under high spring tension and MUST be securely anchored. Failure to secure the track or pad could result in death or serious injury. Anchor into wood stud or structurally sound member. For wood studs on top of masonry or steel jambs, use 1-3/4" lags. DO NOT use nails to secure the track or spring pad. *See Figure 2, page 6

Notes:
* Hand tightening will allow for slight adjustments during the installation.

* Be sure to predrill a 3/16" hole for lag bolts, to prevent splitting of wood.

* 1/4"-20 Hex Nuts always go on the outside of the track.

* If you raise one side of the bottom section to level it, you MUST raise the track on that side the same amount for the door to operate properly.

* Vertical Tracks must be level with each other for the door to function properly. The bottom of the track MUST be equal to the bottom of the section. If not level, raise the lower track but not higher than 3/8" from the floor (Figure 8D). Vertical Tracks must be plumb as well.

* Maintain 3/8" space between the door edge and the vertical track (Figure 8C).

Step 11: Jamb Bracket to Track Attachment (Right Side)

Align the lower Universal Jamb Bracket with the flat side of the track as shown in Figure 7A. Attach with (1) 1/4" x 5/8" Track Splice Bolt and (1) 1/4"-20 Hex Nut, through the oval holes. Hand tighten. Repeat this step for the upper Jamb Bracket. See the Jamb Bracket Location chart for placement (Figure 7).

Step 12: Flag Bracket Attachment (Right Side)
Position the Flag Bracket to the top of the track (Figure 7C). Loosely attach the lower slot of the Flag Bracket to the top of the Vertical Track with (2) 1/4" x 5/8" Track Splice Bolts and (2) 1/4"-20 Hex Nuts and finger tighten.

Step 13: Positioning the Track on the Door (Right Side)

Place the assembled Vertical Track with Jamb Brackets attached over the rollers as shown in Figure 8C & 8D.

Step 14: Mounting the Vertical Track to the Jamb (Right Side)

With both tracks properly aligned, predrill 3/16" holes to prevent splitting of wood, and securely fasten each Jamb Bracket to the jamb with (1) 5/16"x1-5/8" Lag Bolt (Figure 8A).

Step 15: Mounting the Flag Bracket to the Jamb (Right Side)

Predrill 3/16" holes to prevent splitting of wood, and secure the Flag Brackets (keeping them plumb) with (3) 5/16"x1-5/8 lag bolts to the jamb (Figure 8B).

Repeat Steps 11 thru 15 for the left side Vertical Track.

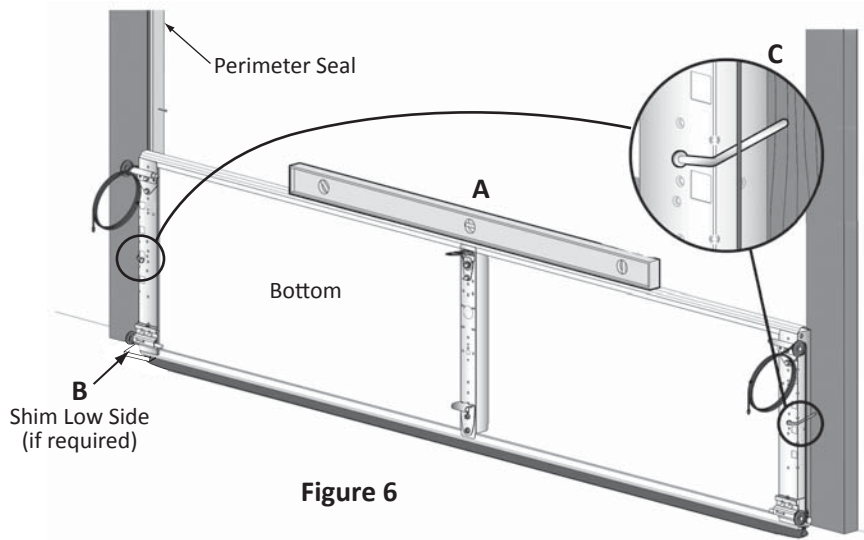

Figure 6

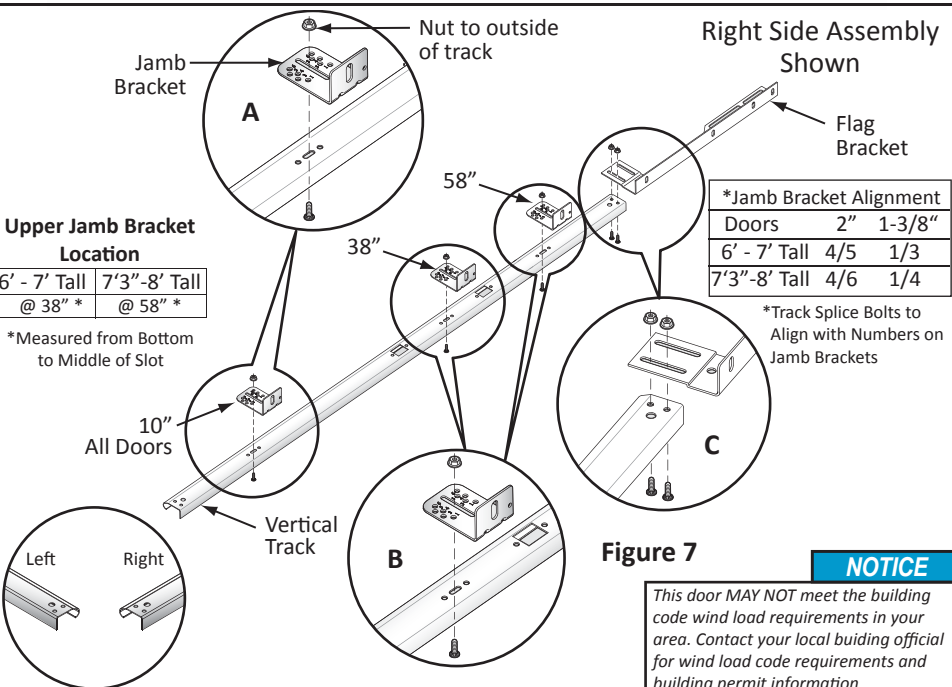

Figure 7

NOTICE

This door MAY NOT meet the building code wind load requirements in your area. Contact your local building official for wind load code requirements and building permit information.

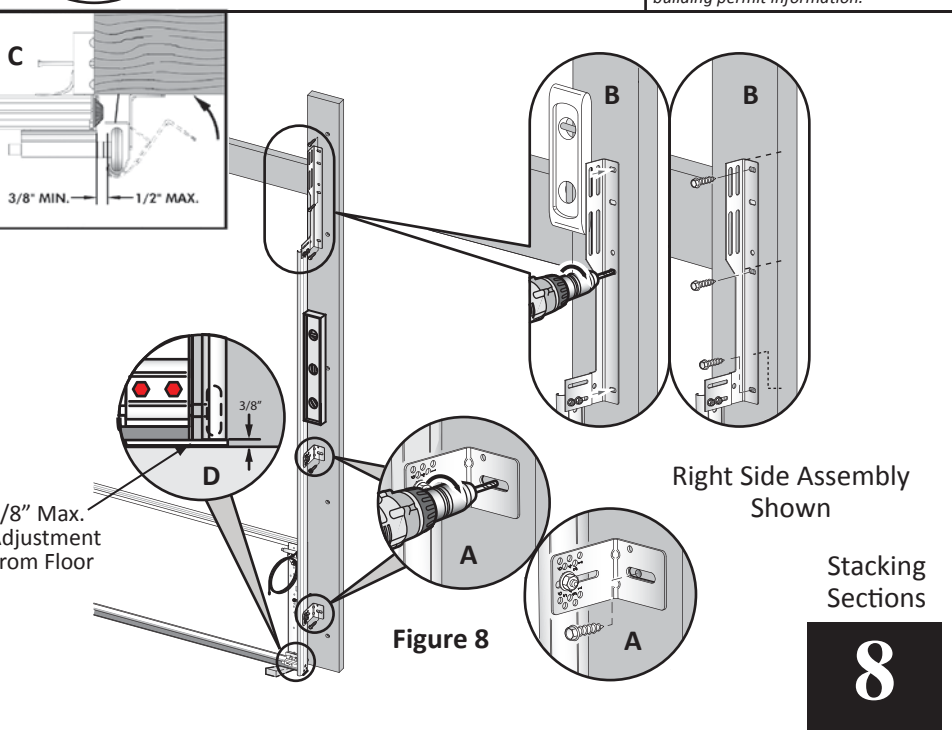

Figure 8

Stacking Sections

Step 16: Installing Intermediate Section Hardware

Place the second section face down on the padded saw horses. Install the Roller Carriers and Rollers as shown on Page 7, Step 6.

Install the Center Hinge(s) as shown on Page 7, Step 7.

Notes:

* "Intermediate" refers to sections above the bottom section and below the top section. Sections are interchangeable (except for 3 section doors which need correct placement to create the various designs).

* If additional reinforcement (struts) are supplied or required with your door, refer to page 12, for proper location.

* Begin with Page 10, Step 22 A or B for Strut Installation and Placement instructions.

Step 17: Stacking Intermediate Section(s) in Opening

Lift the Intermediate Section, with the rollers, roller carriers, center hinges, and struts (if installed). Slide the rollers down into the track (Figure 9). Lower the section down onto the bottom section that you stacked earlier (Figure 10).

Step 18: Finish Center Hinge(s) Installation

Once the section is in place, rotate the upper half(s) of the Center Hinge(s) and attach to the section above with (2) 1/4"x5/8" Universal Screws (Figure 11). Use holes V & W for single and double layer doors. Triple layer doors are not marked, but will line up with the holes in the Center Hinge.

Step 19: End Hinge Installation (Left & Right)

Fit the End Hinges between the track and the section. Align the End Hinge studs with the extruded holes in the edge of the end stiles and insert. Secure the hinge with (2) 1/4"x5/8" Universal Screws (Figure 12). Use holes 19 & 23 for single and double layer doors. Use holes 14 & 18 for triple layer doors.

Firmly hold the End Hinges in place with a screwdriver between the track and the hinge, as you tighten the screws (Figure 12).

CAUTION Pinch and Strike Hazard. Secure the end hinge with appropriate universal screws (see figure 12). Failure to properly secure the hinge could result in minor or moderate bodily injury. Wear work gloves and safety glasses.

Note: Repeat steps 16-19 for each intermediate section required (Figure 13).

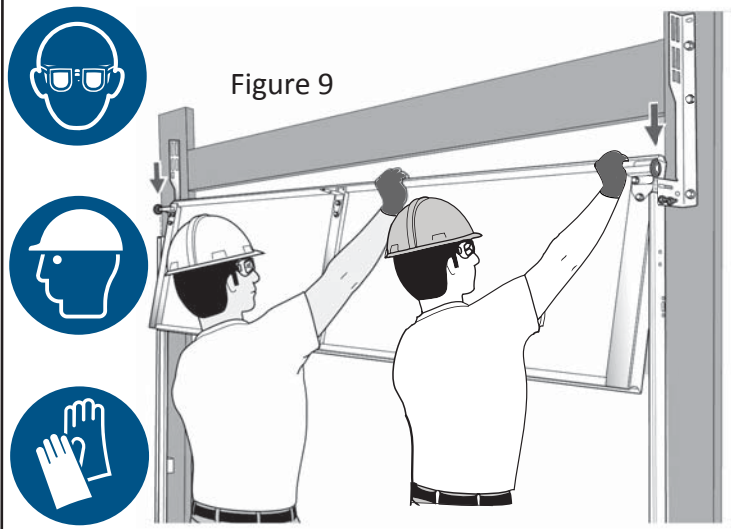

Figure 9

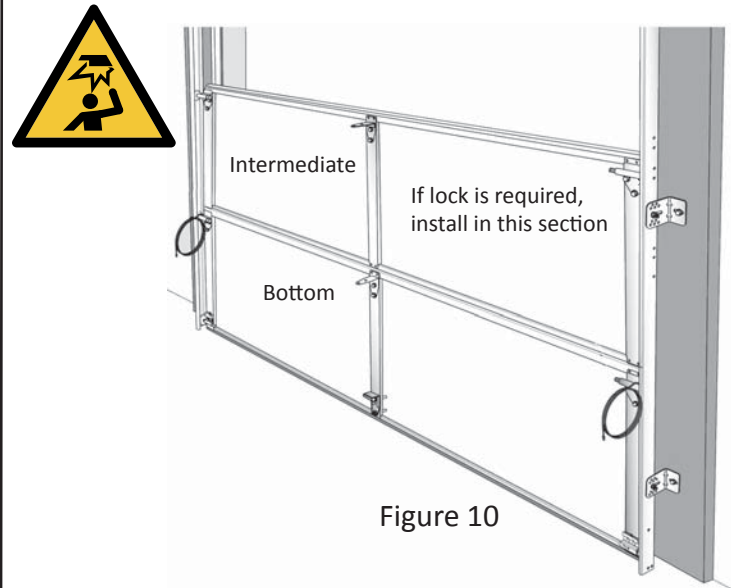

Figure 10

Figure 11

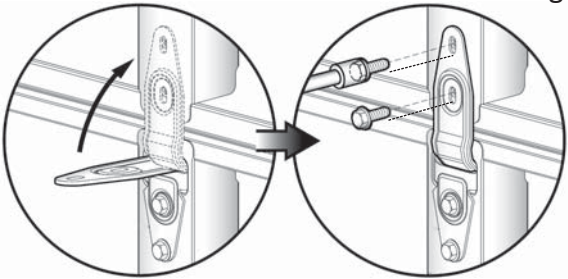
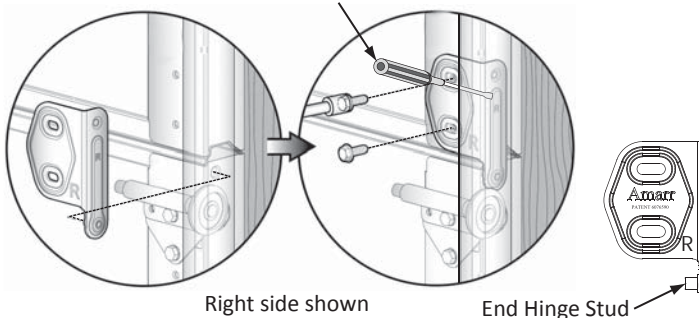

Figure 12

Use Screwdriver to hold End Hinge in place as you tighten screws.



The End Hinge Stud is inserted into the extruded hole in the *side* of the *lower* section. (2) 1/4"-20 x5/8" Universal Screws fasten the End Hinge to the *upper* section.

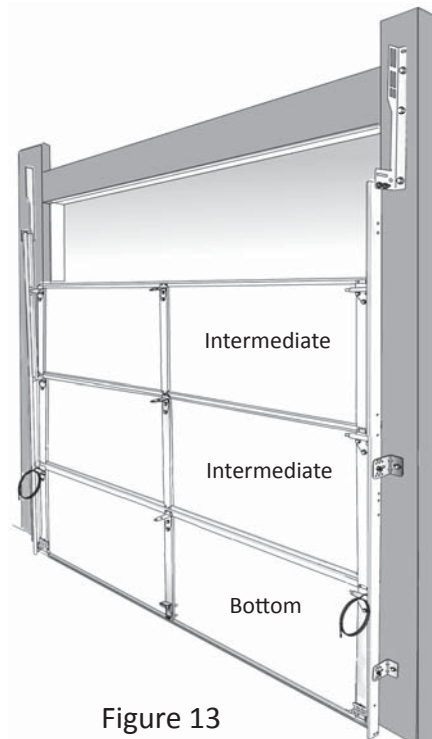

Figure 13

Stacking Intermediate Sections

Step 20: Installing Top Section Hardware

Place the top section face down on your padded saw horses. Locate the Stile Stiffener(s) or Hinge Hole Plugs.

Note: For Single & Double Layer doors, Stile Stiffeners MUST be installed along the top edge of the top section in the center stile hinge pocket(s). If your door has multiple center stiles and Hinge Hole Pockets, there should be one in each pocket.

Step 21: Installing the Stile Stiffener(s)**(Single & Double Layer doors only)**

Position and rotate the Stile Stiffener(s) as shown in Figure 14A. When installed correctly they should appear flat as shown in Figure 14B. Stile Stiffener(s) once installed, do not require any fasteners to secure in position. The side tabs will maintain the part securely in the hinge pocket.

Note: If struts are not required, skip to Step 23.

Step 22A: Strut Installation - (Single & Double Layer doors Only)

If Strut(s) are required, placement is shown on page 12. Install using (2) 1/4"x5/8" Universal Screws into each end and center stile (Figure 15C).

Attach Strut(s) to Stile Stiffener(s) and center stile(s) with (2) 1/4"x5/8" Universal Screws, using the top and bottom holes (Figure 15A).

Step 22B: Strut Installation - Triple Layer Doors

If Strut(s) are required, placement is shown on page 12. Install using (2) 1/4"x5/8" Universal Screws into each end and center stile (Figure 15C). Install the Hinge Hole plug as shown in Figure 15D.

Attach Strut(s) to the center stile with (2) 1/4"x5/8" Universal screws, using the Strut Clip to fasten the Strut to the lower hole (Figure 15D).

Note: Due to lack of available head room (refer to Page 7, Table 1), you may require a Low Head Room application. If this is the case, skip Step 23 and go to Step 24.

Step 23: Top Fixture Installation (Standard Head Room)

Align the Top Fixtures with holes 4,5,&9 (Figure 14C) on the end stiles. Secure the fixture to the end stiles with (3) 1/4" x 5/8" Universal Screws (Figure 14C). Insert Rollers as shown (Figure 14C). Leave the slide loose for adjustment later.

Step 24: Top Fixture Installation (Low Head Room)

Align the Flat Top Fixture (for Low Head Room applications), with holes 1 & 4 (Figure 15B) on the top corner of the end stiles. Secure the fixture to the end stiles with (2) 1/4"x5/8" Universal Screws (Figure 15B). Insert Rollers as shown (Figure 15B). If a strut is required, refer to Step 22 for instructions. The Strut will mount on top of the lower portion of the Low Head Room Flat Top Fixture (Figure 15B).

Step 25: Stacking the Top Section in the Opening

Lift the Top Section, with the rollers, top fixtures and struts (if required). Lower the section on to the previously installed intermediate section. Temporarily secure the top section by driving a 16-penny nail into the header and carefully bending it over (Figure 16A).

Step 26: Center Hinge(s) Installation

Once the top section is secured, rotate the upper half(s) of the Center Hinge(s) and attach to the upper section with (2) 1/4"x5/8" Universal Screws (Page 9, Step 11).

Step 27: End Hinge Installation (Left & Right)

Fit the End Hinges between the track and the section. Align the End Hinge studs with the extruded holes in the edge of the end stiles and insert. Secure the hinge with (2) 1/4"x5/8" Universal Screws (Page 9, Step 19, Figure 12).

Use holes 19 & 23 for single and double layer doors.

Use holes 14 & 18 for triple layer doors.

Firmly hold the End Hinges in place with a screwdriver between the track and the hinge, as you tighten the screws (Page 9, Figure 12).

CAUTION Pinch and Strike Hazard. Secure the end hinge with appropriate universal screws (see Page 9, figure 12). Failure to properly secure the hinge could result in minor or moderate bodily injury. Wear work gloves and safety glasses.

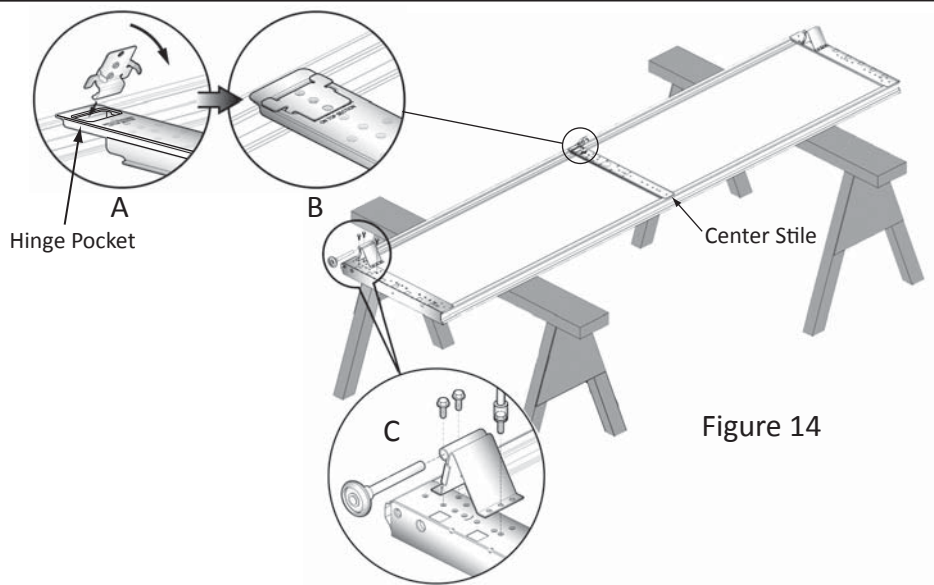

Figure 14

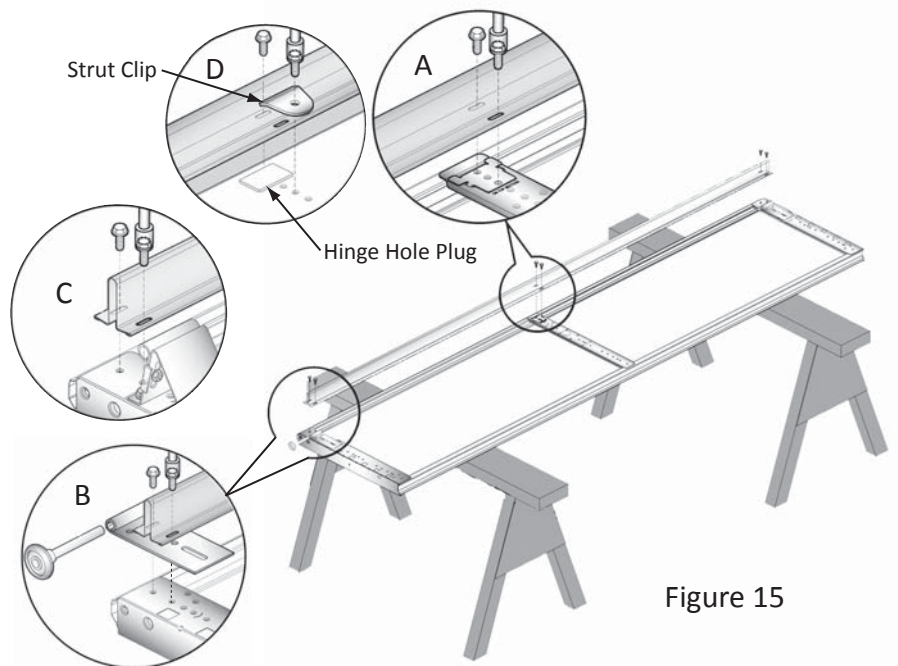

Figure 15

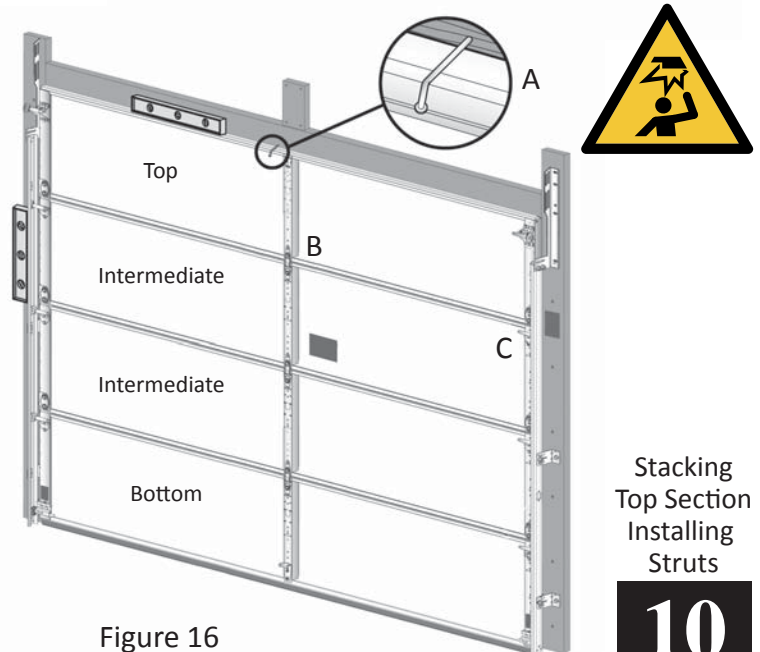

Figure 16

Stacking
Top Section
Installing
Struts

10

Garage Door Opener Bracket Installation
(Required for Triple Layer Doors)

⚠ WARNING *our door did not come with a strut, adding one will change the weight of your door. The increased weight may require using different springs than the ones supplied. Incorrect springs can lead to pre-mature failure of the door. Check with your vendor before proceeding.*

Notes:

* Triple layer doors require the Garage Door Opener Bracket shown to the right (Figure 1A). This bracket is not supplied with your door and must be purchased separately.

* Single and Double layer doors do not require these steps. Your Garage Door Opener will come with an easy to install bracket and instructions for installation.

* All doors that use an ELECTRIC OPENER require a minimum of (1) strut mounted to the top section.

* Before you proceed with Page 10, Step 22B of the Installation Instructions, attach the Garage Door Opener Bracket to the section as shown (Figure 1).

Step 1: Attach the strut to the top of the section following the instructions from Page 10, Step 22B. Before inserting the (2) 1/4"x5/8" Universal Screws in to the middle of the strut, the screws will now go through both the strut and the Garage Door Opener Bracket (Figure 1 & 2). On the lower side of the strut, you will need to use a Strut Clip as shown in Figure 2A.

Step 2: Install your top section as shown in the Installation Instructions (page 10, Step 25-27).

The Opener Bracket will mount on top of the Center Hinge, with (1) 1/4"x5/8" Universal Screw (Figure 3).

Step 3: Attach the Opener Arm to the pin (B) in Figure 2.

For further information concerning installation of your Electric Garage Door Opener, consult the manufacturer's instructions.

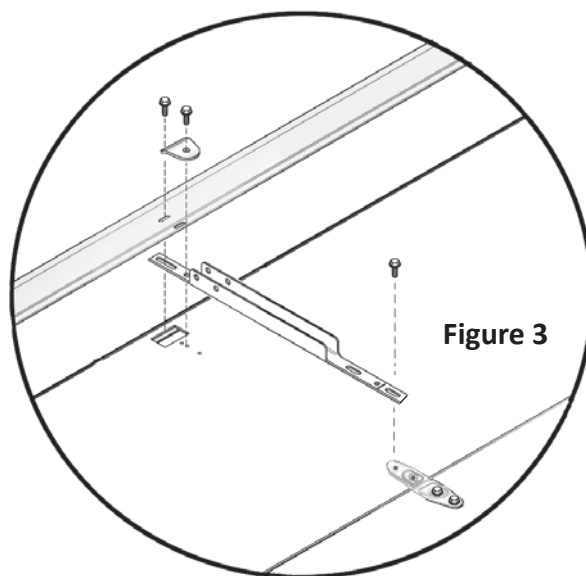
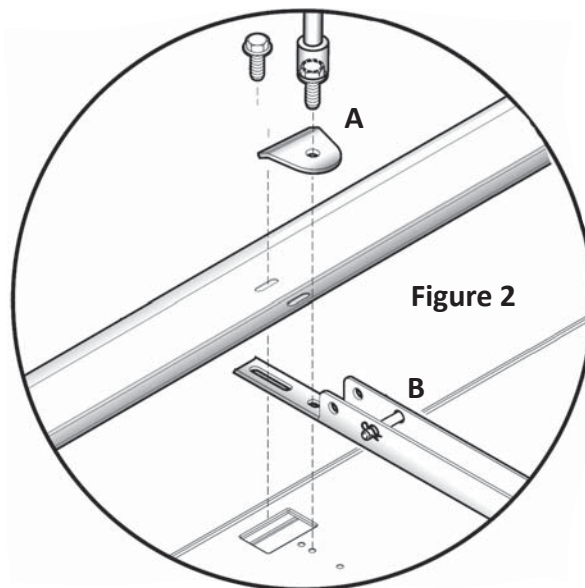
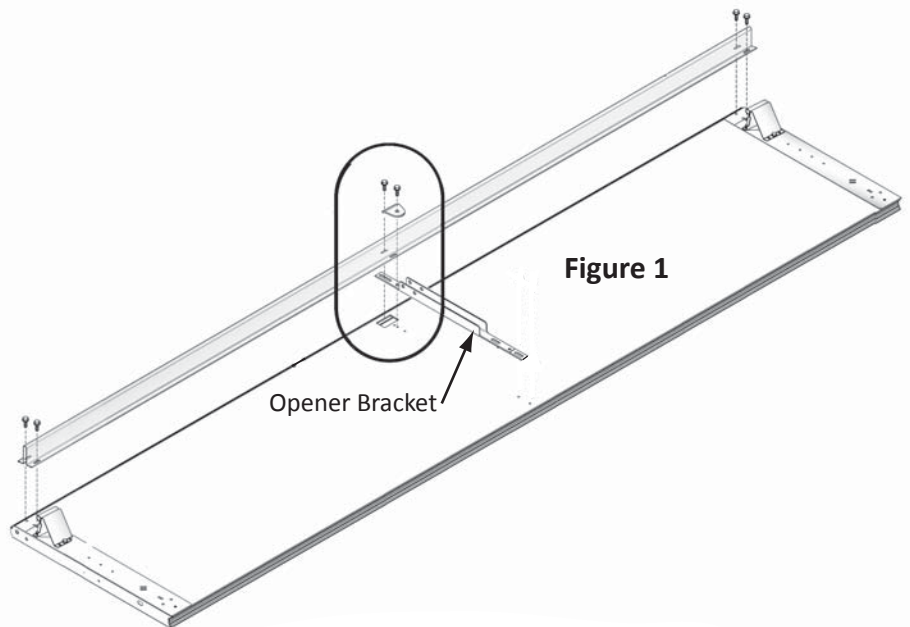

Step 1 of 3: Number of Struts & Strut Size

Model	Door Width	4 Sections	5 Sections
Single Layer / Double Layer Garage Doors	6'-0" - 14'-0"	0 Struts ★	0 Struts ★
	14'-2" - 16'-0"	(1) 2" Strut	(1) 2" Strut
	16'-2" - 18'-0"	(3) 2" Struts	(3) 2" Struts
	18'-2" - 20'-0"	(4) 3" Struts	(4) 3" Struts

★ Minimum (1) strut required, on top section, for doors with opener

Model	Width	4 Sections	5 Sections
Triple Layer Garage Doors	6'-0" - 10'-0"	0 Struts ★	0 Struts ★
	10'-2" - 16'-0"	(1) 2" Strut	(2) 2" Strut
	16'-2" - 18'-0"	(3) 2" Strut	(4) 2" Struts
	18'-2" - 20'-0"	(3) 2" Strut	†(4) 2" Struts

★ Minimum (1) strut required, on top section, for garage doors with opener

† Not Available for 1-3/8" thick Triple Layer doors

Model	Width	3 Sections
3 Section Garage Doors Single, Double & Triple Layer Garage Doors	6'-0" - 14'-0"	0 Strut ★
	14'-2" - 16'-0"	(2) 2" Struts
	16'-2" - 18'-0"	(3) 3" Struts

★ Minimum (1) strut required on, top section, for garage doors with opener

★ Minimum (1) strut required on window section.

ELECTRIC OPENER ATTACHMENT

When installing a garage door opener, the following applies:

1. The garage door springs must be in good working order and the door must be balanced (should be able to raise the door half way and have the door stay in place).
2. The top section of the garage door MUST include a strut (see Page 10, Step 22 A or B).
3. Disconnect and/or remove all locks and pull ropes. Attempting to use the opener while door is locked will damage your garage door. FAILURE TO DO SO WILL VOID DOOR WARRANTY.

NOTICE

This garage door MAY NOT meet the building code wind load requirements in your area. Contact your local building official for wind load code requirements and building permit information.

Many Amarr garage doors have engineering drawings to meet wind load requirements. Garage doors must be assembled precisely as shown in the drawings.

Strut Detail Example (non-windload garage door):
16'-0" width x 8'-0" tall - Double Layer - (5) Sections
(information from table top left of page)

Step 1: Number of struts - (1) 2" Strut

Step 2: Strut Location - Top of Top Section - 1st Strut Position

Step 3: Strut Attachment - Above Top Fixture to End Stile - (A)
and top Center of Door on Stile Stiffener - (B)

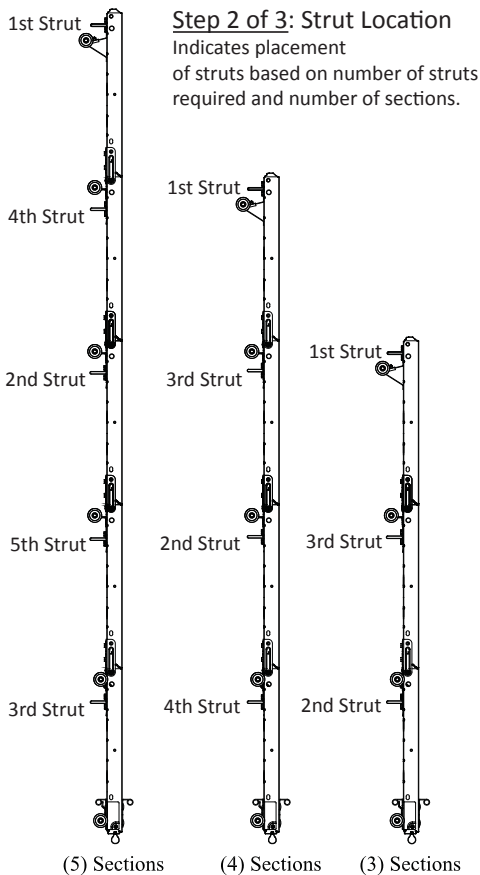

Step 3 of 3: Strut Attachment

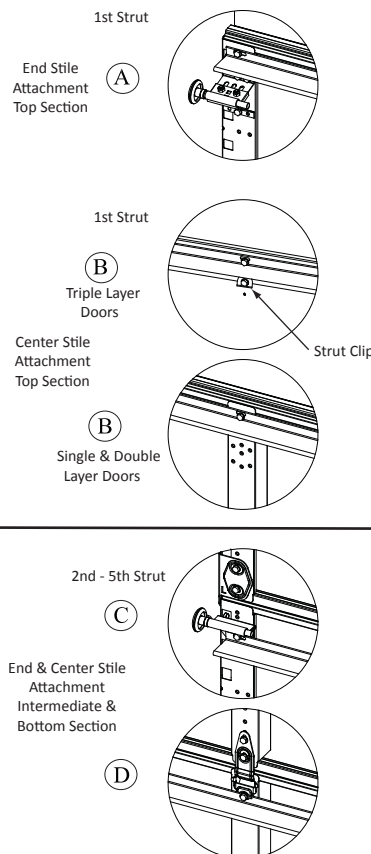

SEE PAGE 10, STEP 22A OR B FOR INSTALLATION DETAILS.

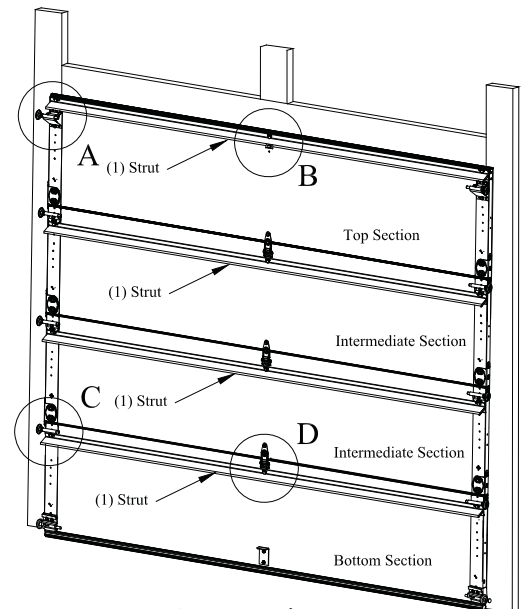

Strut Attachment Key

Strut Information & Installation

12

Note: For doors requiring a Low Head Room Installation (check Page 7, Table 1), see Page 18 or 19 for installation instructions.

Step 28: Horizontal Track to Flag Bracket Attachment Part 1 (Left Side Assembly shown)

Place the curved end of the Horizontal Track Assembly over the roller in the Top Fixture and attach to the Flag Bracket with (2) 1/4"x5/8" Track Splice Bolts and (2) 1/4"-20 Hex Nuts (Figure 17A). Temporarily support the back end of the track using a rope or wire attached to the ceiling to support the back end of the track.

Note: 1/4"-20 Hex Nuts always go on the outside of the track.

Step 29: Horizontal Angle to Flag Bracket Attachment Part 2
Attach the end of the Horizontal Angle to the Flag Bracket with (1) 3/8"x3/4" Low Shoulder Carriage Bolts and (1) 3/8"-16 Hex Nut (Figure 17B).

Note: For 2" thick doors use the slot on the Flag Bracket, farthest from the jamb. For 1-3/8" thick doors use the slot closest to the jamb.

Note: 3/8"-16 Hex Nuts always go on the outside of the assembly (away from the door).

Step 30: Back Hanger Installation (see Page 14 or 15)

Replace support rope or wire with metal Angle Hangers (Purchased separately, recommend minimum 14 gauge) (Figure 17C & E). Back Hangers need to be level and plumb. Angle must fasten securely to studs.

WARNING BACK HANGERS MUST BE ABLE TO SUPPORT THE WEIGHT OF THE TRACK AND THE DOOR.

Note: Installer is responsible to separately purchase and install framing and metal Back Hangars and fasteners for each installation.

Note: Repeat steps 28 - 30 for Right Side Horizontal Assembly.

Important: Horizontal Track must be spaced no more than 3/8" from the sections to prevent the sections from falling out of the track.

Make sure that the distance between the track and the door is equal at the bottom of the Vertical Track, at the curve of the horizontal, and at the back of the Horizontal Track (approximately 3/8").

Step 31: Inspecting the Track Installation

Using a tape measure and level, make sure the track is level and square with the opening (Figure 17). Adjustment to the track position may need to be made later, after the springs are installed and the door is opened to maintain the proper spacing of 3/8".

Step 32: Adjusting the Top Fixture

With the door in the closed position, tighten the slide on the Top Fixture by pushing the top section tight against the opening and lightly pulling the top slide toward the inside of the garage (Figure 17D). Tighten the nuts.

Step 33: Remove all Temporary Nails

Step 34: Pull Rope Installation (no Electric Opener only)

If an electric opener is not used, attach one end of the pull rope to the Safety Bottom Bracket and the other end to the second Jamb Bracket. To prevent accidents, **DO NOT INSTALL PULL ROPE IF ELECTRIC OPENER IS USED.**

WARNING Go to page 16 for Torsion Spring Installation Instructions. Go to page 21 or 22 for Extension Spring installation instructions. After springs are installed, proceed to Step 35.

Step 35: Secure the Perimeter Seal

Close the door from the outside and permanently nail the Perimeter Seal for a snug fit so that the seal does not bind the door. Wax the inside, hard edge of the seal to prevent binding (if necessary).

Step 36: Install Safety Stickers to Door

Install supplied Safety Stickers as shown in Fig 17. If these are not supplied, call 877-512-6277 for replacement stickers.

Step 37: Final Check

- A. Make sure there is a 3/8" clearance between the door and the track along the entire horizontal and vertical track assemblies. Adjust as necessary.
- B. Make sure the garage door is square with the opening.
- C. If the door does not operate easily, make sure that the door to track spacing is correct and that the door is not binding.

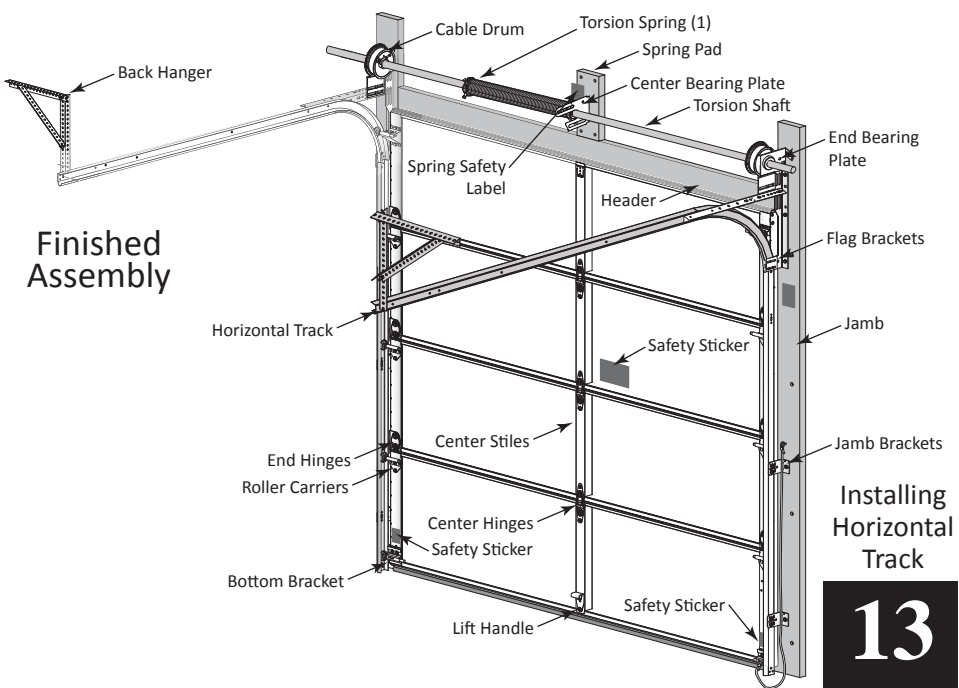
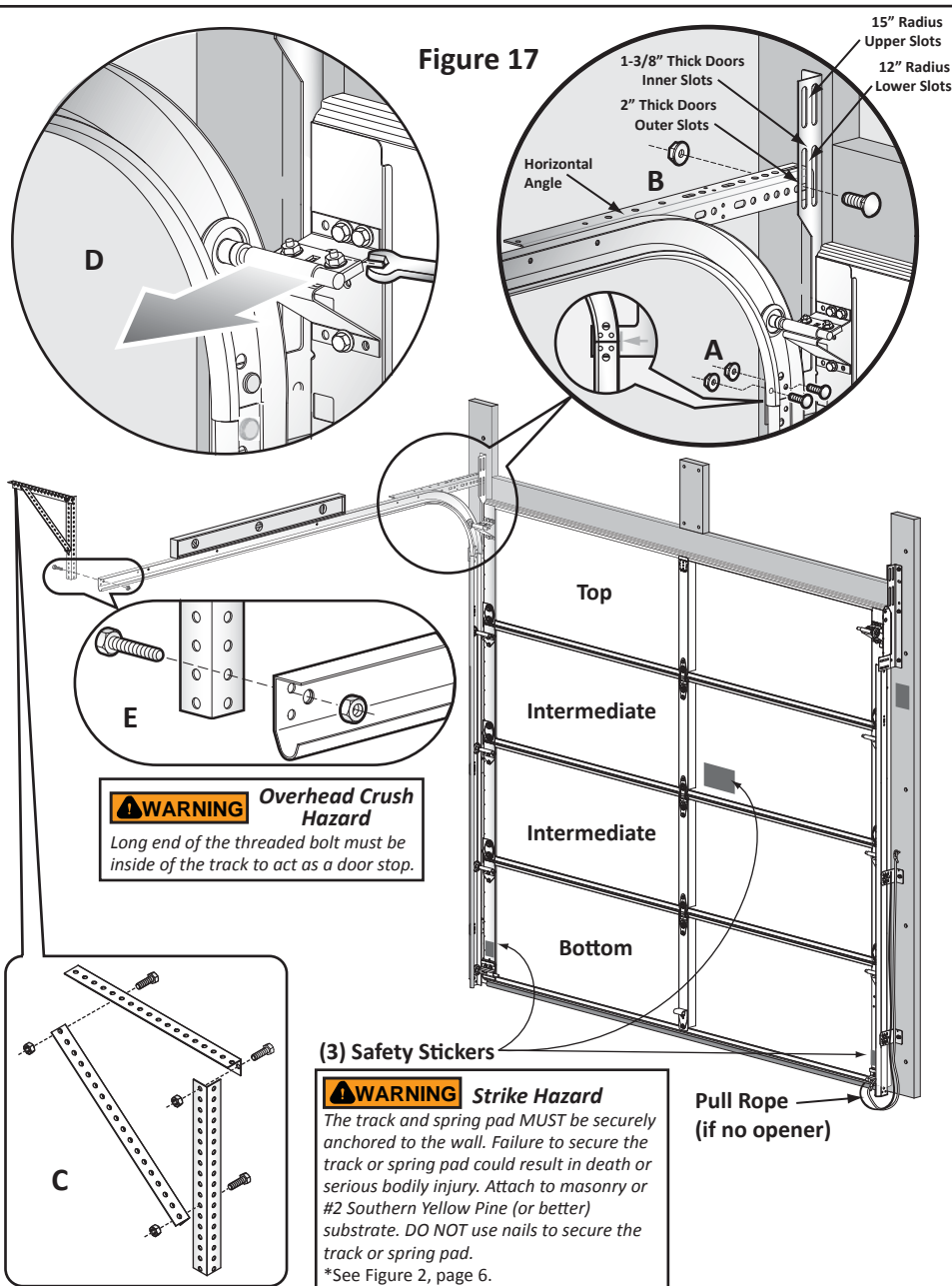

Back Hanger Installation Instructions (Track parallel to joists)

Note: Garage doors are not supplied with Back Hanger or fasteners. These items must be purchased separately.

Note: Hanger Angles must be a minimum of 14 gauge.

Step 1: (Right Side shown) Keeping the horizontal track square, level, and parallel to each other, mark a spot on your ceiling directly above the end of the horizontal track (Fig 1).

Note: If your ceiling is not finished in sheet rock, skip to step 3.

Step 2: Using a hammer, tap around your mark to find a ceiling joist/beam and mark the spot (Figure 2, 3, & 4). Then, move to the right or left approximately 18"-24" and tap around to find a second ceiling joist/beam (Figure 2 & 3).

Step 3: Mark and cut a piece of angle to span the distance between the ceiling joists/beams plus 4" (Figure 8 & 9).

Note: Predrill the two 3/16" holes to prevent splitting of the wood.

Step 4: Securely fasten each end of the angle to the ceiling joists/beams using (2) 5/16"x1-5/8" Lag Bolts (Figure 5 & 6).

Step 5: Measure the distance from the bottom of the Horizontal Track to the top of the angle (Figure 7). Mark and cut a piece of angle this distance (Figure 8 & 9).

Step 6: Mark and cut a piece of angle to form a 45° brace (Figure 8, 9, & 10). This piece should be about the same length as the piece in Step 5. Securely fasten the Back Hanger Angles using (3) 3/8"x1-1/2" Machine Bolts and (3) 3/8"-16 Hex Nuts as shown in Figure 10.

Step 7: (Standard Lift) Securely fasten the vertical Back Hanger Angle to the Horizontal Track using (1) 3/8"x1-1/2" Machine Bolt and (1) 3/8"-16 Hex Nut (Figure 11).

Step 7: (Low Head Room) Securely fasten the vertical Back Hanger Angle to the Upper Low Head Room Horizontal Track using (1) 3/8"x1-1/2" Machine Bolt and (1) 3/8"-16 Hex Nut (Figure 12).

Note: Hex Nut is mounted to inside of track to act as door stop.

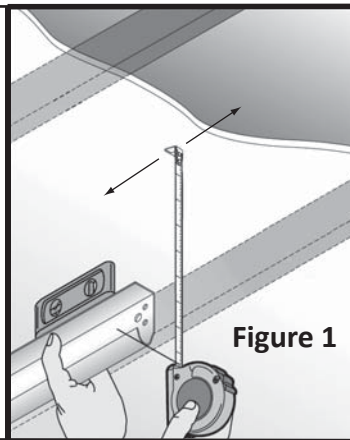

Figure 1

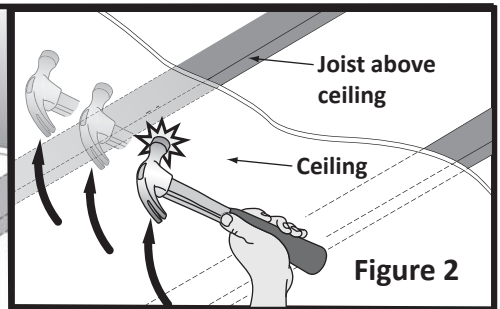

Figure 2

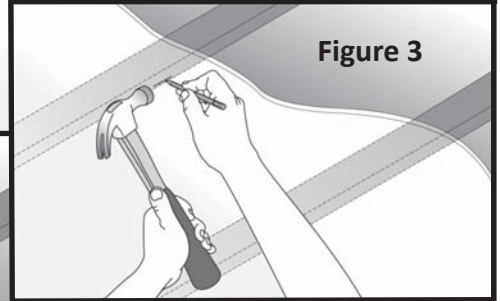

Figure 3

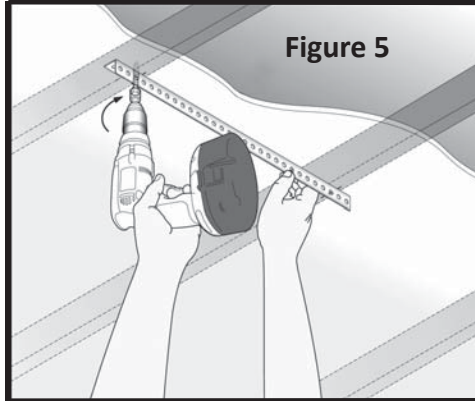

Figure 5

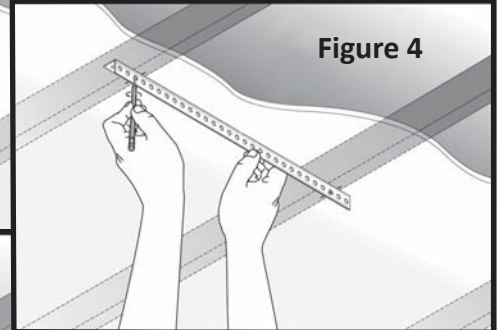

Figure 4

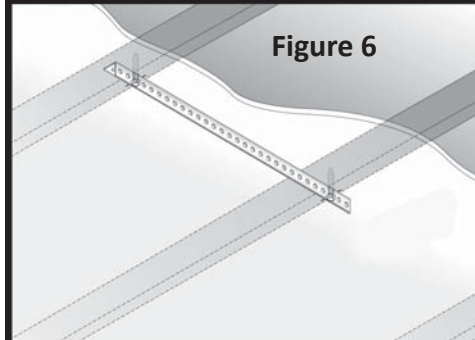

Figure 6



OVERHEAD CRUSH HAZARD

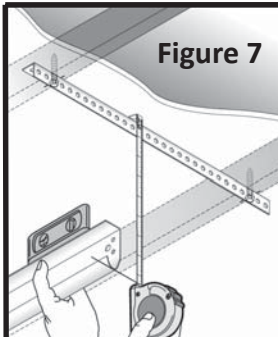

Figure 7

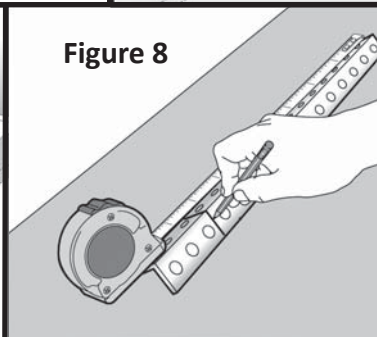

Figure 8

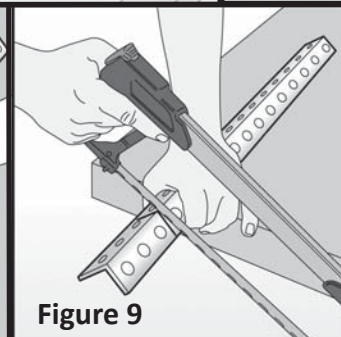

Figure 9

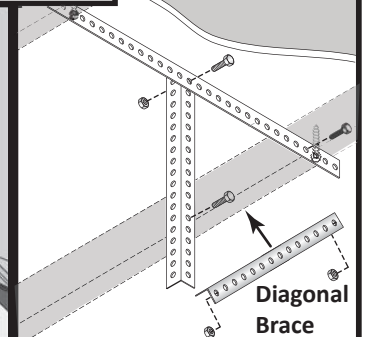

Figure 10

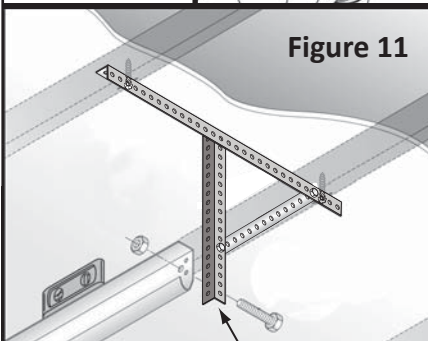

Figure 11

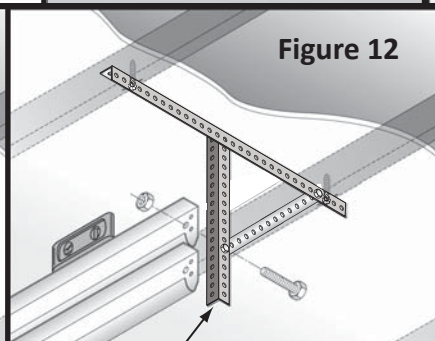
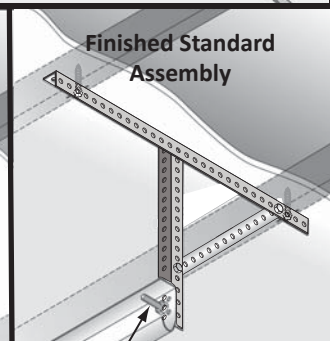
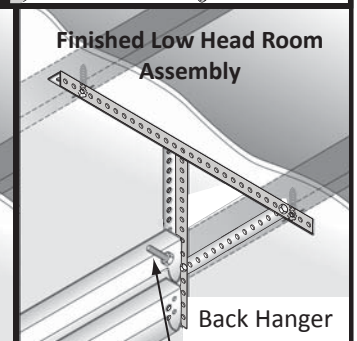

Figure 12



Finished Standard Assembly



Finished Low Head Room Assembly

- Strike Hazard - Sharp Edges
- Risk of death or serious bodily injury
- Track Hanger must not extend below horizontal track



WARNING



- Strike Hazard - Risk of Door Falling
- Risk of death or serious bodily injury
- Long end of threaded bolt must be inside of the track to act as a door stop

Back Hanger Installation

14

THIS PAGE IS INTENTIONALLY LEFT BLANK

Torsion Spring Installation Instructions

⚠️ WARNING High Spring Tension

DO NOT remove, repair or adjust springs or anything to which garage door spring parts are fastened, such as wood blocks, steel brackets, cables or other like items. Failure to follow these instructions could result in death or serious bodily injury. Repairs and adjustments must be made by a trained door system technician using proper tools and instructions.

Note: Garage doors may be supplied with 1 or 2 Torsion Springs. Directions for installation are the same.

Note: Garage doors may be supplied with extension springs. See Pages 21 or 22 for details.

Note: Garage doors may be supplied with a spring winding device. See instructions provided by the manufacturer, in the box for details.

Step 1: End Bearing Plate Attachment (Left Side)

Note: Use ladder where required.

Attach the left side End Bearing Plate to the Flag Bracket and Horizontal Angle with (2) 3/8"x3/4" Low Shoulder Carriage Bolts and (2) 3/8"-16 Hex Nuts (Figure 1A & B).

Note: 3/8"-16 Hex Nuts always go to the outside of the Flag Bracket. Secure the Tab on the End Bearing Plate, to the Jamb/Spring pad with (1) 5/16"x1-5/8" Lag Bolt (Figure 2A). Pre-drill a 3/16" pilot hole to prevent splitting the wood.

Repeat Step 1 for the Right Side End Bearing Plate

Step 2: Torsion Spring Unit Installation:

Note: Assemble these components while working on the ground.

Slide the left side (Red) drum onto the shaft. The Set Screws should be facing toward the center of the shaft. Next, slide the left side Torsion Spring (Red) onto the shaft, with the set screws facing toward the outside of the door, then slide the Nylon Bearing onto the shaft (the Nylon Bearing should be turned so it is able to slide into the spring, Figure 3A). If your door requires (2) springs, slide the Right/Black spring on facing in the opposite direction of the Left/Red spring. Slide on the right side (Right/Black) drum with the set screws facing toward the middle.

Step 3: Installing the Torsion Spring Unit

Keeping the shaft level, slide the complete Spring Assembly into the Left and then Right side End Bearing Plates (Figure 3). There should be an equal amount of the shaft protruding from each End Bearing Plate (Figure 3).

Step 4: Installing the Center Bearing Plate

The Center Bearing Plate must be mounted in the center of the shaft, and level with the End Bearing Plates so the shaft is level. Fasten the Center Bearing Plate to the 2"x6" Wooden Spring Anchor Pad with (2) 5/16"x1-5/8" RED Lag Bolts (Figure 3B). Pre-drill a 3/16" pilot hole to prevent splitting the wood.

Note: DO NOT remove warning label (hang tag) from the center bearing plate.



Step 5: Securing the Spring(s)

Slide the spring against the Center Bearing Plate, with the Nylon Bearing inserted into the spring (Figure 3A). Using (2) 3/8"x1-1/2" bolts and (2) 3/8-16 RED Hex Nuts, fasten the spring(s) to the Center Bearing Plate (Figure 3C). If two springs are required, the screws go through both Springs and the Center Bearing Plate. Tighten securely.

Step 6: Installing the Lift Cables

Bring the Left Side Lift Cable up between the door and the track, behind the Torsion Shaft and over the Left Side Drum. Slide the drum against the End Bearing Plate. Hook the Cable Stop into the notch on the outside edge of the drum (Figure 4). Turn the drum with your hand until the cable is snug. Using only your fingers, tighten the (2) Set Screws on the drum finger tight, until they touch the tube. Then, turn each screw 1/2 to 1 turn with a 3/8" wrench.

Note: Do not over tighten the Set Screws, this could damage the Torsion Shaft.

Using a pair of Lock Pliers, clamp the shaft from the outside of the End Bearing Plate, so that the cable does not loosen or unwind (Figure 3D). The back of the Lock Pliers should rest solidly against the jamb/header. This will prevent the drum from unwinding or rising up as you wind the spring.

Repeat Step 6 for the Right Side Cables and Drum.

Step 7: Winding the Torsion Spring(s)

Mark a straight line on the Spring(s) with a piece of chalk (Figure 6A & B). Insert the Winding Bars completely into the full depth of the holes in the Winding Cone. Always wind pushing the Winding Bars up (Figure 5A & B) 1/4 turn at a time. When the correct number of turns are on the spring(s) (Table 3 & Figure 6 Step 3), keeping tension with the Winding Bar, using only your fingers, tighten the Set Screws on the spring(s) finger tight. Then, turn 1/2 to 1 turn with a 3/8" wrench.

Note: Do not over tighten the Set Screws, this could damage the Torsion Shaft.

Remove the Winding Bars and the Lock Pliers.

Note: There should be no tension on the Winding Bars.

Test your installation by working the door up and down. The door should balance (not go up or down) at 2', 3' and 4' off the floor.

Proceed to Step 35, Page 13 to finish the installation.

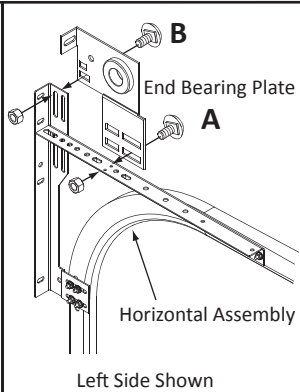

Figure 1

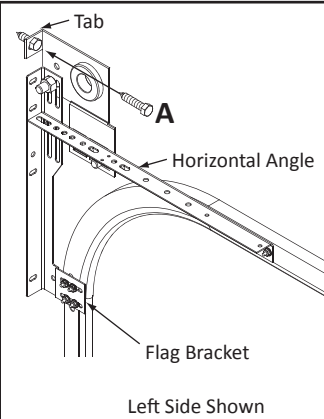

Figure 2

Table 3 - Number of Turns Required for Springs

Door Height	Turns 12 Radius	Turns 15 Radius	Turns LHR
6'-0"	6.7	7.1	6.3
6'-2"	6.9	7.2	6.4
6'-3"	7.0	7.3	6.5
6'-5"	7.2	7.4	6.6
6'-6"	7.2	7.5	6.7
6'-9"	7.4	7.7	6.9
6'-10"	7.5	7.8	7.1
7'-0"	7.6	7.9	7.2
7'-1"	7.7	8.0	7.3
7'-4"	8.0	8.2	7.5
7'-6"	8.1	8.4	7.6
7'-8"	8.2	8.5	7.8
7'-9"	8.3	8.6	7.9
8'-0"	8.5	8.8	8.1

Note: For doors over 8' tall, call 1-800-503 DOOR.

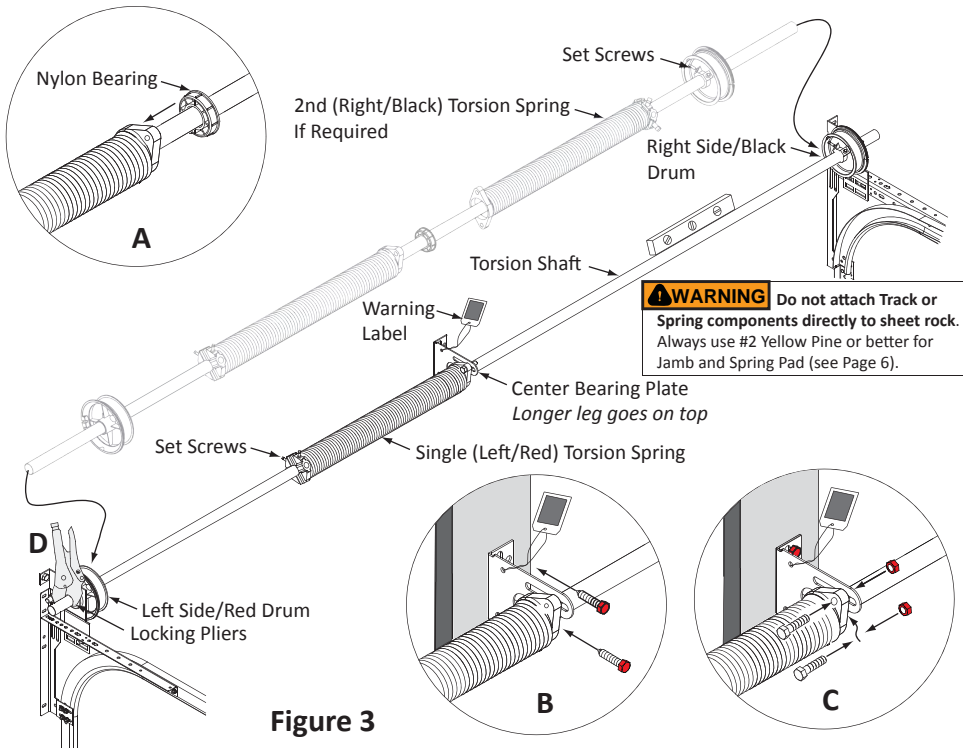

Figure 3

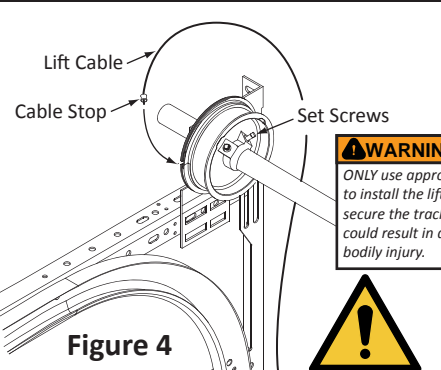

Figure 4

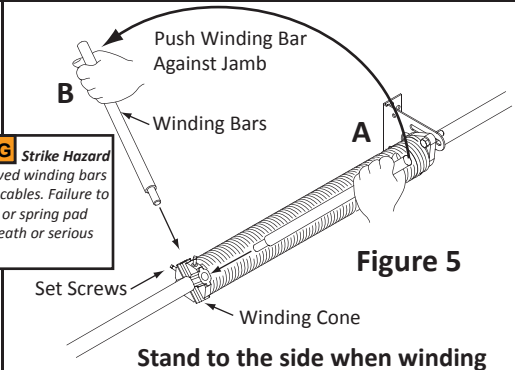

Figure 5

Stand to the side when winding

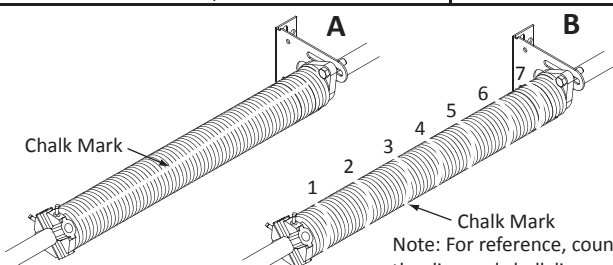

Figure 6

Torsion Spring Installation

NOTICE

Failure to comply with these instructions invalidates the warranty. Before you begin the installation, read all of the instructions thoroughly.

Slide Lock Installation Instructions

NOTICE Do not install Slide Locks if your garage door is equipped with an Electric Garage Door Opener.



NOTICE Locks (including Slide Locks) will damage your Electric Garage Door Opener and your garage door if the lock is engaged when the operator tries to raise the garage door. **This will invalidate the garage door warranty.**

NOTICE If you are going to install an Electric Garage Door Opener later, remember to remove or disable the Slide Locks. You can disable the lock by opening the dead bolt and putting a lock or bolt through the lock hole (Figure 4).

Note: Garage doors may not be supplied with Slide Locks and fasteners. These items must be purchased separately.

Note: These instructions show a Double Layer garage door but apply to Single and Triple layer garage doors as well.

NOTICE It is best to knock out the tab on the track from the inside of the track, before the track is installed.

Step 1: (Right Side) Using a hammer and punch, knock out the pre-punched rectangular metal tab from the Horizontal Track (Figure 1).

Step 2: With your door in the fully closed position, locate your lock so that the slide will line up with the center of this rectangular hole (Figure 3 & 4). Securely fasten the Slide Lock to the 2nd section with (2) 1/4"x5/8" Universal Screws (Figure 2). You may need to pre-drill 3/32" pilot holes if holes in the section do not line up with this location.

Step 3: With your door in the fully closed/down position, test the Slide Lock for ease of operation. Adjust the lock up or down if necessary (Figure 3 & 4).

If a second lock is requested, repeat Steps 1-3 for the left side.

NOTE: Second lock is not required.

NOTE: Other locks may be provided with your garage doors. Refer to installation instructions included with the lock for details.

Figure 1

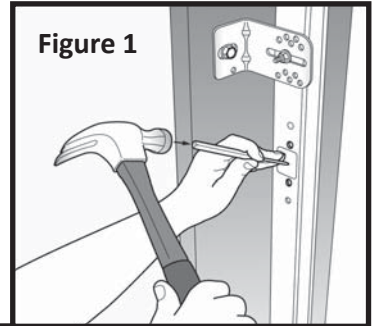

Right Side

Figure 2

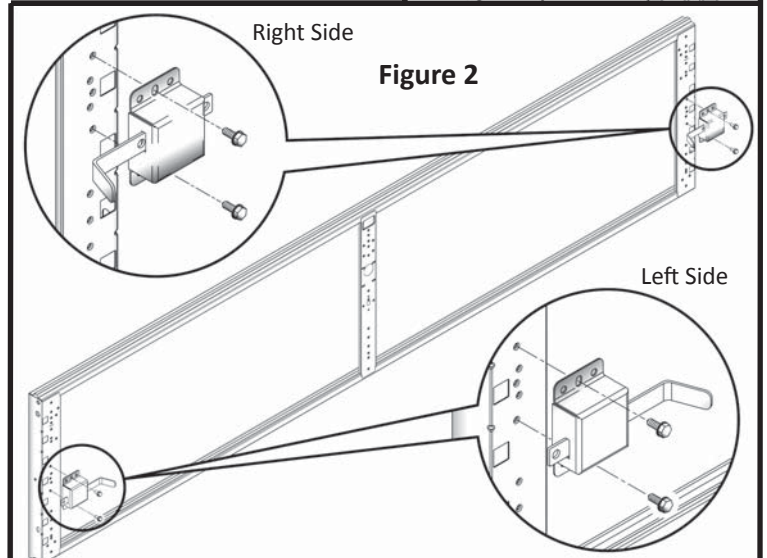

Left Side

Figure 3

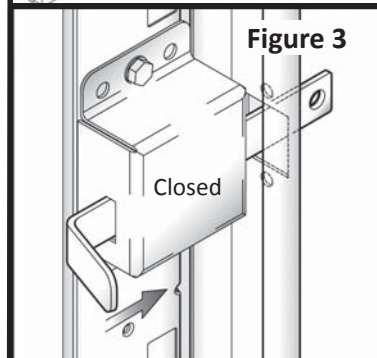
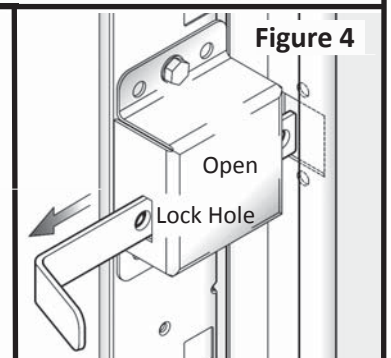

Figure 4



Perimeter Seal Installation Instructions

Note: Garage doors are not supplied with Perimeter Seal or fasteners. These items must be purchased separately.

Note: The Perimeter Seal shown here has a vinyl flap. Perimeter Seal is available with no flap. Skip Step 8 for seal with no vinyl flap.

Note: A Hacksaw is required for smooth, accurate cuts.

Step 1: Measure horizontally across the top of your Header (Figure 1). This may require two people to hold the tape measure.

Step 2: Mark your first piece of Perimeter Seal for cutting (Figure 2).

Step 3: Using a Hack Saw (Figure 3), carefully cut the Perimeter Seal to length.

Step 4: Starting at the end (Figure 4), tap the fasteners halfway into the seal, beginning at 6" from the end and continuing every 12" on center.

Step 5: Holding the seal in place (the edge with the flap should be flush with the inside of the jamb) (Figure 5 & 6), hammer the fasteners partially into the jamb. This will allow for slight adjustments later.

Step 6: Measure the vertical (left side) of your Jamb (Figure 1). Mark your second piece of Perimeter Seal for cutting (Figure 2).

Step 7: Using a Hack Saw (Figure 3), carefully cut the Perimeter Seal to length.

Step 8: Cut a 45° angle through the molding where it meets the top, horizontal piece (Figure 7). This will allow the flap on the horizontal seal to lay down flush with your door.

Step 9: Starting at the top (Figure 4), tap the fasteners halfway into the seal, beginning at 6" from the top and continuing every 12" on center.

Step 10: Holding the seal in place (the edge with the flap should be flush with the inside of the jamb) (Figure 8), hammer the fasteners partially into the jamb. This will allow for slight adjustments later.

Repeat Steps 6 - 10 for the right side Perimeter Seal.

Step 11: When your door is installed, balanced and closed with either the operator or lock, you may completely nail the Perimeter Seal to the jambs, after making any slight adjustments as required for a tight seal and smooth operation.

Note: If the seal is too tight against the garage door, the door may become difficult to raise and lower, and could result in damage, that will void the warranty.

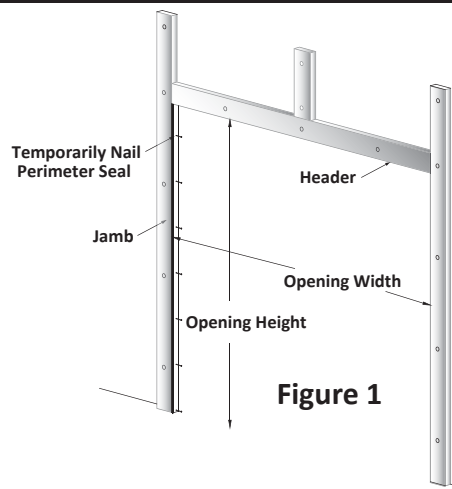
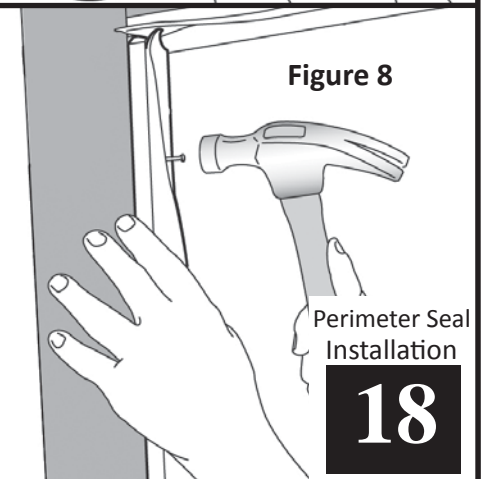
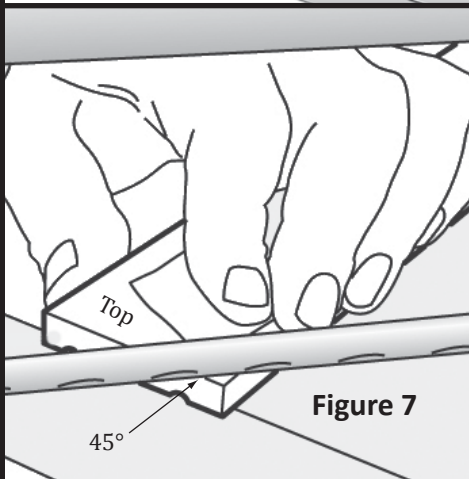
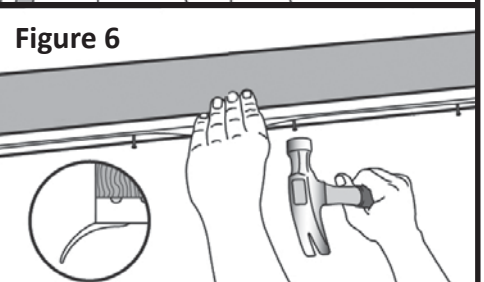
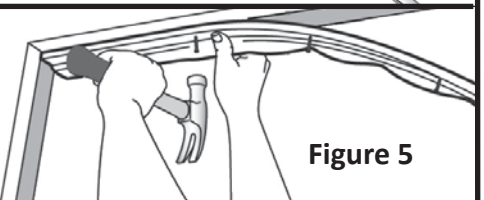
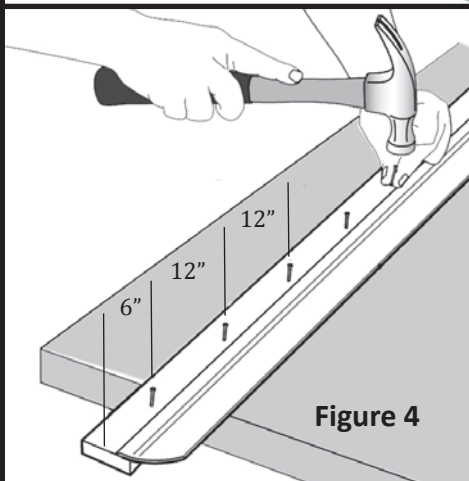
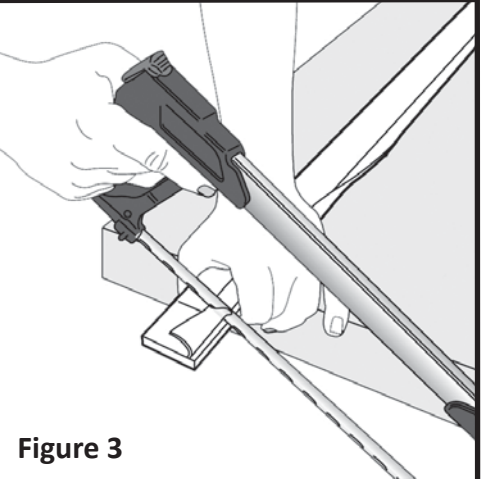
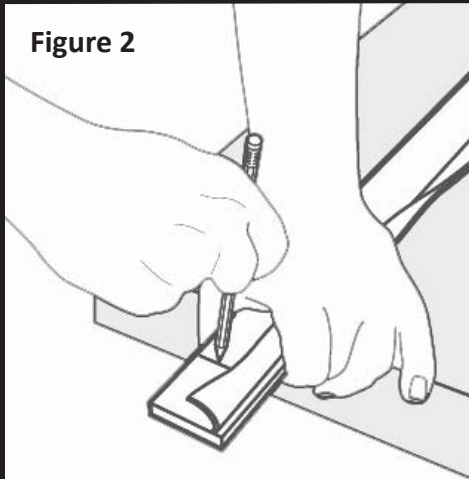

Figure 2



Perimeter Seal Installation

Low Head Room Front (LHF) Track Installation Instructions

Step 1: Horizontal Track to Flag Bracket Attachment (Left Side Assembly Shown)

Place the curved end of Upper Horizontal Track assembly over the roller in the top fixture (refer to page 10, step 24 for Low Head Room Top Fixture installation) and attach to the flag bracket with (2) 1/4"x5/8" Track Splice Bolts and (2) 1/4"-20 Hex Nuts (Figure 1A). Temporarily support the back end of the track using a rope or wire attached to the ceiling.

Note: 1/4"-20 Hex Nuts always go to the outside of the track.

Note: In a Low Head Room installation, only the Top Rollers go into the Upper Horizontal Track. All other Rollers go into the Lower Horizontal Track.

Step 2: Starter Plate to Flag Bracket Attachment

Attach the end of the Starter Plate to the Flag Bracket with (1) 3/8"x3/4" Low Shoulder Carriage Bolt and (1) 3/8"-16 Hex Nut (Figure 1B).

Note: 3/8"-16 Hex Nuts always go on the outside of the assembly (away from the door).

Step 3: Track Hanger Installation SEE PAGE 14 FOR DETAILS.

Note: Repeat steps 1-3 for Right Side Horizontal Track to Flag Bracket Attachment.

WARNING Track needs to be spaced 3/8" from the sections to prevent the sections from falling out of the track.

Step 4: Inspecting the Track Installation

Make sure track is level and square with the opening (Figure 1). Make sure that the distance between the track and the door is the same at the bottom of the vertical track, at the curve of the horizontal, and at the back of the horizontal track (approximately 3/8"). Adjustment to the track position may need to be made later, after the door is opened to maintain the proper spacing.

Step 5: Remove all Temporary Nails

Step 6: Pull Rope Installation

If an electric opener is not used, attach one end of the pull rope to the Safety Bottom Bracket and the other end to the second jamb bracket.

For Torsion Spring Installation, go to page 16.

For Extension Spring Installation, go to page 21 for Standard Lift or page 22 for Low Headroom.

After the springs are installed, proceed to page 13, Step 35 to finish the installation.

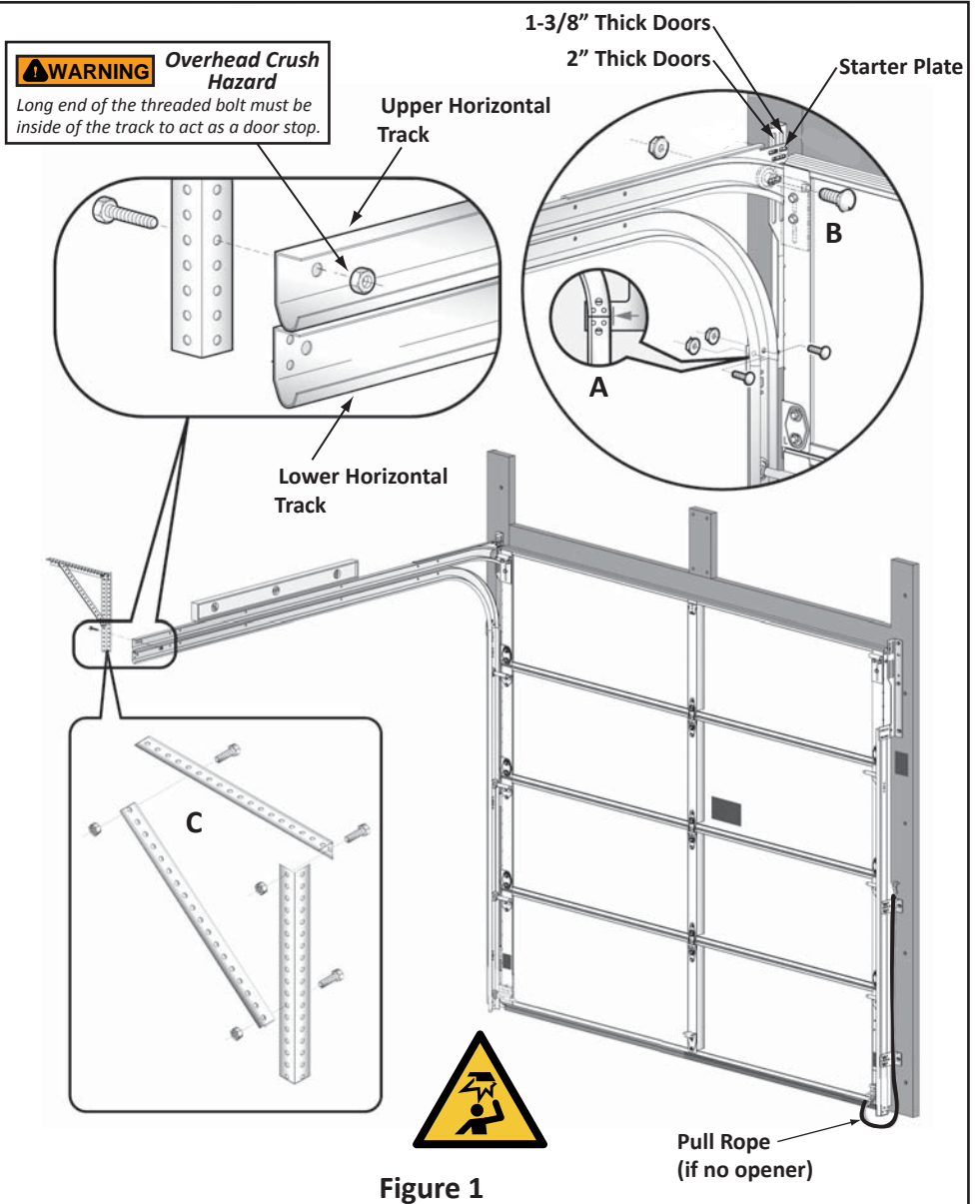
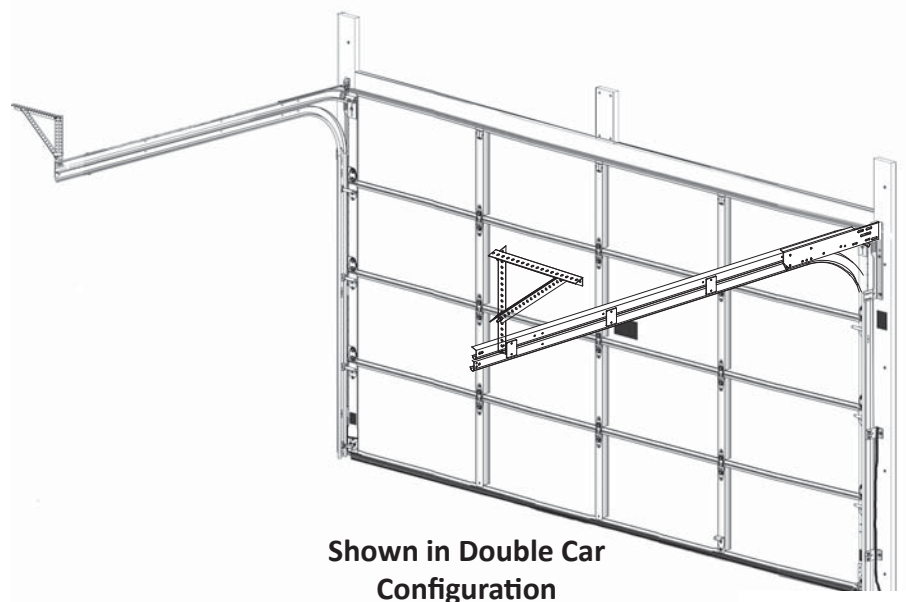

Figure 1



Shown in Double Car Configuration

Low Head Room Installation

Low Head Room Rear (LHR) Mount Track Installation Instructions

Step 1: Attach the Outside Hook-Up (OHU) Bottom Bracket to the bottom of the section. Install the (OHU) Bottom Bracket into holes #21, #22, & #18 as shown in Fig 1, using (3) 1/4"x5/8" RED Universal Fasteners. Repeat for the left side Bottom Bracket.

Step 2: Attach the Track Hangers as shown on Page 14 (Left & Right). Do not fasten to end of track. Fasten next to the Junction Plate as shown in Fig 2 (right shown).

Step 3: Fasten the Right Side Flat End Bearing Plate as shown in Fig 3, using (2) 3/8"x1-1/2" Machine Bolts and (2) 3/8"-16 Hex Nuts as show (Fig 3). Repeat this step with the Left Side Flat End Bearing Plate.

Step 4: Install the Torsion Shaft with the Spring(s) and Nylon Bearing, through the Flat End Bearing Plates (Fig 4).

Note: Springs are reversed due to Outside Hook-Up. Black Cone spring mounts on the left, Red Cone spring mounts on the right.

Step 5: Using the Torsion Shaft as a reference and keeping the shaft level, install an additional Track Hanger assembly to support the Center Bearing Plate (Fig 5).

Note: This Track Hanger and Center Bearing Plate must be centered in the middle of the Torsion Shaft.

WARNING Overhead Crush Hazard. Use additional lag bolts to secure the track hanger to the ceiling. Failure to secure the track could result in death or serious bodily injury. Anchor into wood stud or structurally sound member. DO NOT use nails to secure the track or hanger.

Step 6: Attach the Center Bearing Plate to the center Track Hanger with (2) 3/8"x1-1/2" RED Machine Bolts and (2) 3/8"-16 RED Hex Nuts (Fig 5).

Note: Be sure the Torsion Shaft is level.

Step 7: Install the Left Side/Black Cone Spring and Nylon Bearing as shown in Figure 5. Attach the spring to the Center Bearing Plate with (2) 3/8"x1-1/2" RED Machine bolts and (2) 3/8"-16 RED Hex nuts.

Step 8: Install the Cable Drum (marked Black) onto the right side of the shaft as shown in Figure 6. Slide the Cable Drum (marked Red) on the left side of the shaft, outside of the track, as shown in the assembled drawing.

Step 9: Attach a pulley to the right side Sheave Support (Fig 7A) with (1) 3/8"x1-1/2" RED Machine bolt and (1) 3/8"-16 RED Hex nut. Repeat for the left side Pulley.

Step 10: Attach the Sheave Support to the Starter Plate, with the pulley attached (Fig 7B) in a slot and hole, between the upper and lower horizontal track, with (2) 1/4"-20x1 Machine bolt and (2) 1/4"-20 Hex Nuts. Repeat for the left side Sheave Support.

Step 11: Attach the looped end of the Lift Cable to the right side OHU Bottom Bracket (Fig 1 & 6). Loop the cable over the Pulley and run back under the Drum, inserting the cable stop into the slot in the Drum. Repeat for the left side Drum.

Step 12: Pull Rope Installation

If an electric opener is not used, attach one end of the pull rope to the Safety Bottom Bracket and the other end to the second jamb bracket.

For Torsion Spring Installation, go to page 16 to continue.

After the springs are installed, proceed to page 13, Step 35 to finish the installation.



WARNING Overhead Crush Hazard
Long end of the threaded bolt must be inside of the track to act as a door stop.

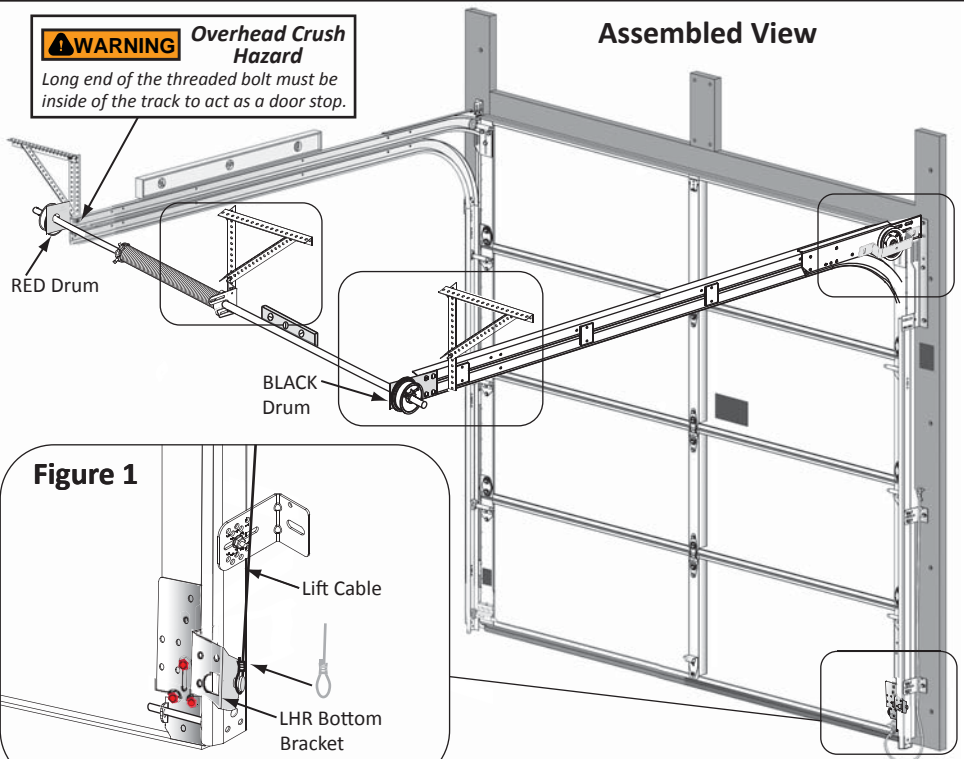
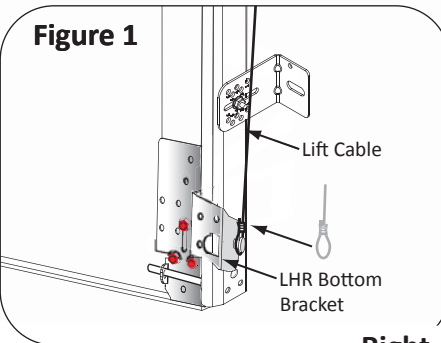

Figure 1



Right Side Shown

Figure 2

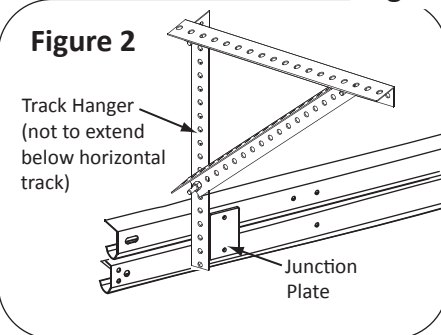

Figure 3

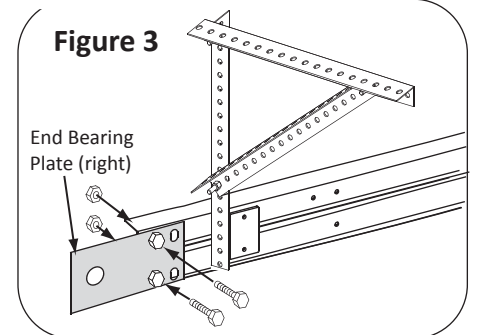

Figure 4

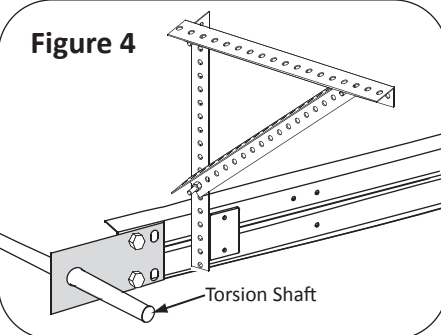

Figure 5

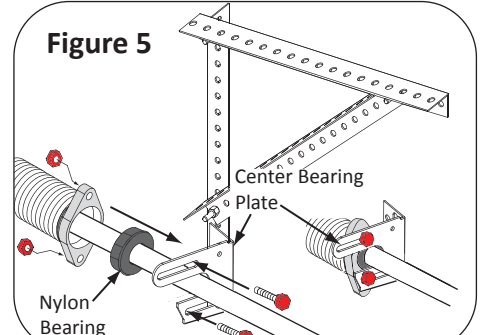

Figure 6

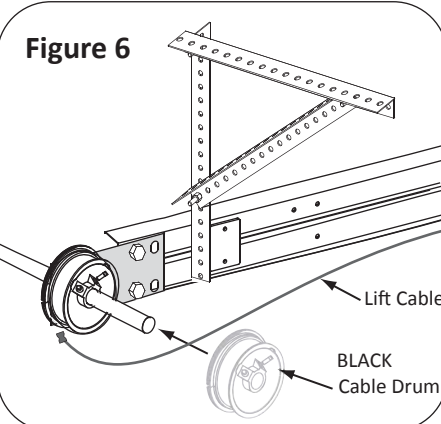
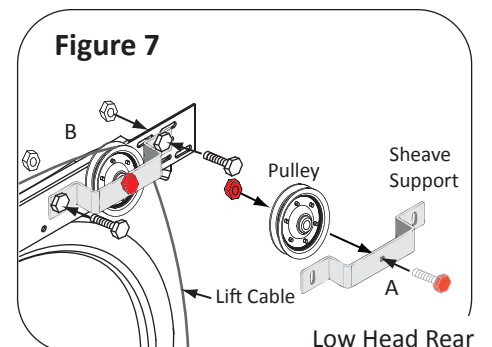

Figure 7



Low Head Rear Installation

Extension Spring Installation Instructions Standard Lift

Step 1: Bolt the Stationary Pulley (right side) to the inside of the Horizontal Angle, through the 3rd open hole out from the jamb, using (1) 3/8"x1-1/2" machine bolt and 3/8"-16 RED nut (Figure 1). Be sure the Pulley turns freely.

Note: Bolt and nut go to outside of horizontal angle.

CAUTION HEAVY. Use two person assisted lifting/handling during overhead work. Failure to secure the track may result in minor or moderate bodily injury.

Step 2: Remove any nails remaining in the jamb. Then, two people should carefully raise the door half-way to check spacing of the Horizontal Track (sections should be spaced no more than 3/8" from track).

When it is determined that the track spacing is correct, raise the door to the fully opened position. Clamp the door open using (2) Lock Grip pliers as shown (Figure 2), one on left and right verticals.

Step 3: Attach the Eye Bolt to the right side diagonal Hanger Angle using (2) 5/16" RED nut (Figure 3). One Red nut goes to the inside and one to the outside to lock the Eye Bolt in place. If your door comes with (4) Extension Springs, you will need (2) Eye Bolts and (4) nuts.

Step 4: Attach a Pulley and Sheave Fork to one end of the Extension Spring using (1) 3/8"x1-1/2" machine bolt and 3/8"-16 RED nut (Figure 4). If your door comes with (4) Extension Springs, refer to Figure 4 (Two Springs)

Step 5: Attach the other end of the Extension Spring(s) to the right side Eye bolt (Figure 5).

Note: Be sure the Safety Retention Cable goes through the nylon guide in the Sheave Fork (Figure 4). This guide will prevent the cable from rubbing against the nut and bolt as the springs stretch.

Step 6: Your door will be supplied with (4 or 6) cables. The longer cables are the Lifting Cables and the shorter cables are the Safety Retention Cables. Install one of the Safety Retention (shorter) Cables as shown in Figure 6 (right side). For two springs, install two Safety Retention Cables.

NOTE: Be sure to loop the cable around the Hanger Angle and then run the cable through the spring.

Step 7: Attach the looped end of the Lifting (longer) Cable to the Cable Button on the right side Bottom Fixture (Figure 7). Then bring the cable up and over the right side Stationary Pulley as shown in Figure 7.

Step 8: Attach the "S" Hook to the right side Horizontal Angle (Fig 8) in a hole approximately 9"-12" back from the header.

Step 9: Run the Lifting Cable back to the Pulley attached to the spring and loop the cable over the top, going through the Sheave (Fig 9).

Step 10: Attach the Cable Adjustment Clip to the loose end of the Lifting Cable, exactly as shown in Figure 10.

Step 11: Attach the Cable Adjustment Clip to the "S" Hook (Figure 11). Be sure to pull out all of the slack in the cable at the Cable Adjustment Clip so the Extension Spring hangs near horizontally (Figure 13). Loop any additional cable to keep it out of the way (Figure 12)

Step 12: Tie the remaining Safety Retention Cable(s) through a hole in the Horizontal Angle between the "S" hook and the jamb (Figure 12). Loop any additional cable to keep it out of the way (Figure 12).

REPEAT STEPS 1- 12 FOR THE LEFT SIDE

CAUTION Overhead Fall Hazard. DO NOT stand under the door during installation. Failure to secure the track may result in minor or moderate bodily injury.

Step 13: Remove the Lock Pliers from the track. Close the door halfway. If the door moves down, shorten the length of both Lift Cables at the Cable Adjustment Clip. Lengthen these cables if the door moves up.

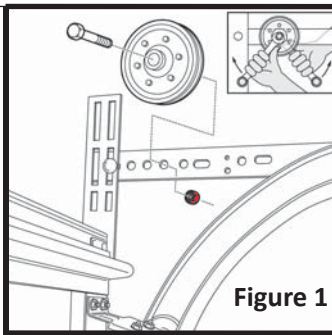

Figure 1

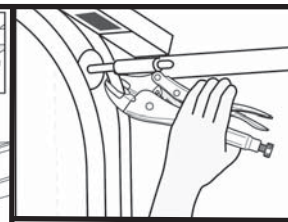

Figure 2

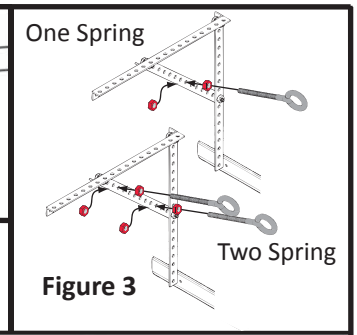

Figure 3

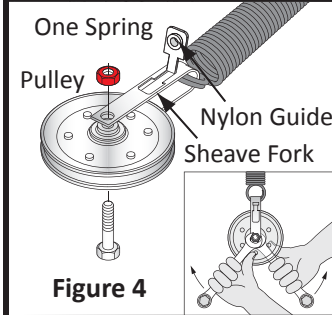

Figure 4

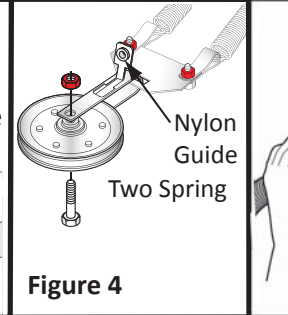

Figure 4

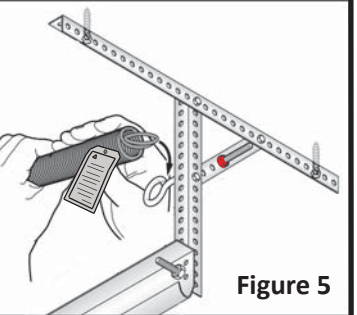

Figure 5

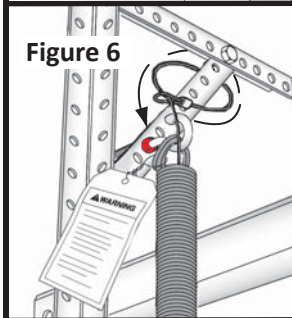

Figure 6

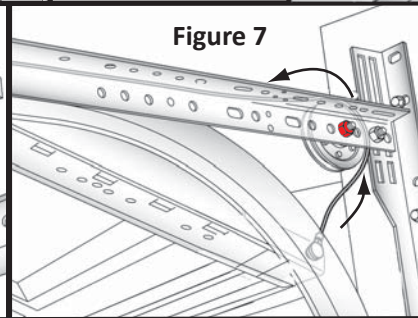

Figure 7



OVERHEAD
CRUSH
HAZARD

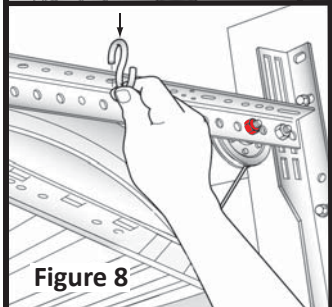

Figure 8

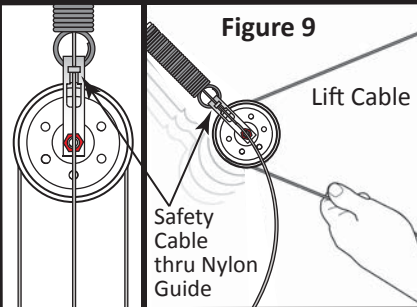

Figure 9

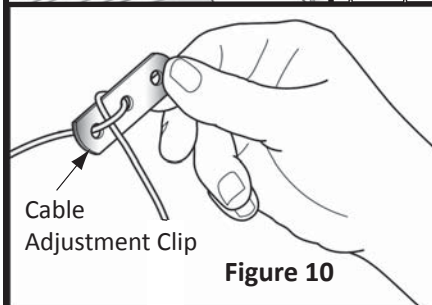

Figure 10

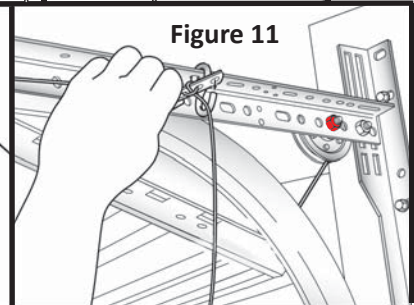

Figure 11

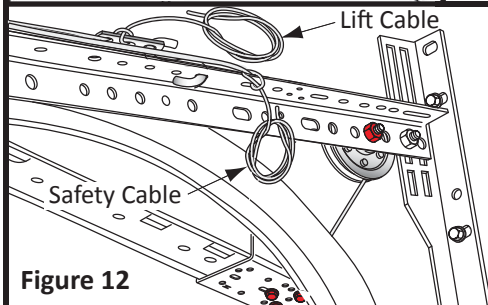

Figure 12

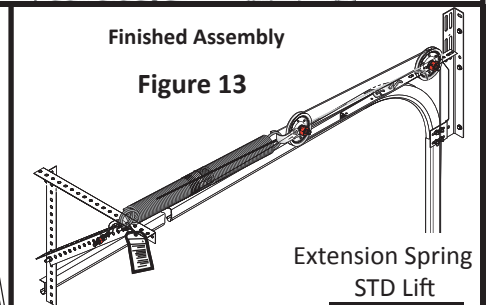

Figure 13

Extension Spring
STD Lift

Low Head Room (LHR) Extension Spring Installation Instructions

Step 1: Attach the Low Head Room Bottom Bracket to the bottom of the section. Install the Out Side Hook-Up (OHU) Bottom Bracket into holes #21, #22, & #18 as shown in Figure 1, using (3) 1/4"x5/8" RED Universal Fasteners. Repeat for the left side Bottom Bracket.

Step 2: Bolt the Stationary Pulley (right side) to the slot in the LHR Starter Plate (Figure 3) between the upper and lower track, using (1) 3/8"x1-1/2" machine bolt and (1) 3/8"-16 RED nut. Be sure the Pulley turns freely.

CAUTION HEAVY. Use two person assisted lifting/handling during overhead work. Failure to secure the track may result in minor or moderate bodily injury.

Step 3: Remove any nails remaining in the jamb. Then, two people should carefully raise the door half-way to check spacing of the Horizontal Track (sections should be spaced no more than 3/8" from track). When it is determined that the track spacing is correct, raise the door to the fully opened position. Clamp the door open using (2) Lock Grip pliers as shown (Figure 2), on left and right verticals.

Step 4: Attach the Eye Bolt to the right side diagonal Hanger Angle using (2) 5/16" RED nuts (Figure 7). One Red nut goes to the inside and one to the outside to lock the Eye Bolt in place. If your door comes with (4) Extension Springs, you will need two Eye Bolts and (4) nuts per side (Figure 7 & 8, Two Spring).

Step 5: Attach a Pulley and Sheave Fork to one end of the Extension Spring using (1) 3/8"x1-1/2" machine bolt and (1)3/8"-16 RED nut (Figure 4, one spring). If your door comes with (4) Extension Springs refer to Figure 5 & 6, Two Spring.

Step 6: Attach the other end of the Extension Spring(s) to the right side Eye bolt (Figure 9).

Step 7: Your door will be supplied with (4 or 6) cables. The longer cables are the Lifting Cables and the shorter cables are the Safety Retention Cables. Install one of the Safety Retention (shorter) Cables as shown in Figure 10 (right side). For two springs, install two Safety Retention Cables.

Note: Be sure the Safety Retention Cable goes through the nylon guide in the Sheave Fork (Figure 4). This guide will prevent the cable from rubbing against the nut and bolt as the springs stretch.

Note: Be sure to loop the cable around the Hanger Angle and then run the cable through the spring.

Step 8: Attach the looped end of the Lifting (longer) Cable to the Cable Button on the right side Bottom Fixture (Figure 1). Then bring the cable up and over the right side Stationary Pulley as shown in Figure 3.

Step 9: Attach the "S" Hook to the right side LHR Starter Plate (Figure 14) in a slot approximately 4"-6" back from the header.

Step 10: Run the Lifting Cable back to the Pulley attached to the spring and loop the cable under the pulley, going through the Sheave (Figure 9).

Step 11: Attach the Cable Adjustment Clip to the loose end of the Lifting Cable (Figure 11).

Step 12: Attach the Cable Adjustment Clip to the "S" Hook (Figure 11 & 14). Be sure to pull out all of the slack in the cable at the Cable Adjustment Clip so the Extension Spring hangs near horizontally (Figure 14 & 15). Loop any additional cable to keep it out of the way (Figure 13)

Step 13: Attach the Cable Adjustment Clip(s) to the Safety Retention Cable(s) (Figure 12). Fasten the clip(s) to the jamb using (1) 5/16"x1-5/8" Lag Bolt (Figure 12 & 13).

Note: Pre-drill a 3/16" hole to prevent splitting of the wood.

REPEAT STEPS 1- 13 FOR THE LEFT SIDE.

CAUTION Overhead Fall Hazard. DO NOT stand under the door during installation. Failure to secure the track may result in minor or moderate bodily injury.

Step 14: Remove the Lock Pliers from the track. Close the door halfway. If the door moves down, shorten the length of both Lift Cables at the Cable Adjustment Clip. Lengthen these cables if the door moves up.

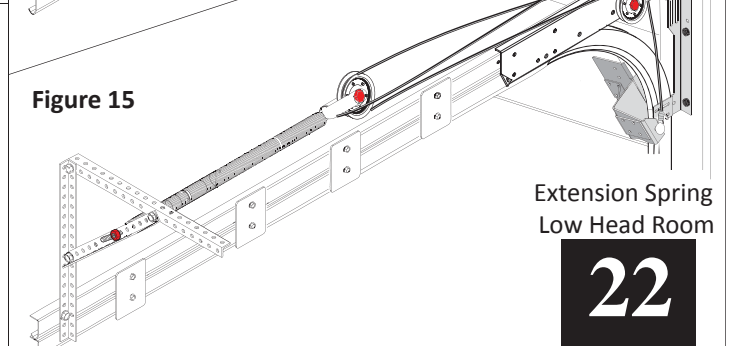
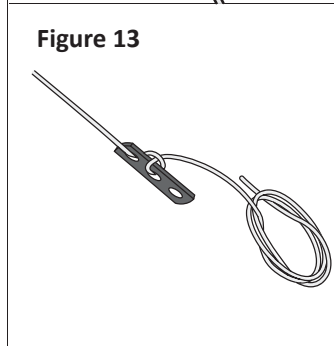
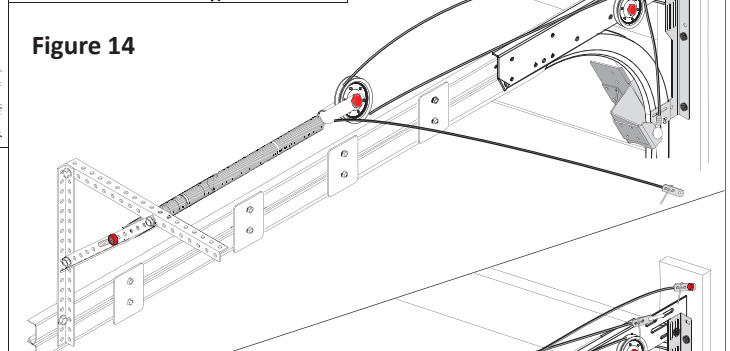
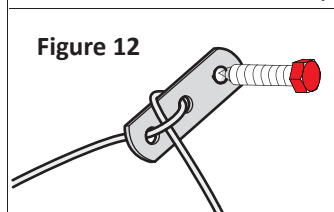
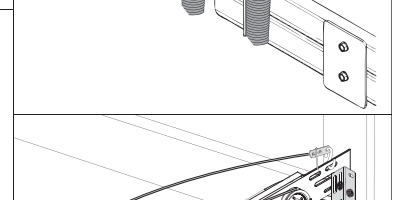
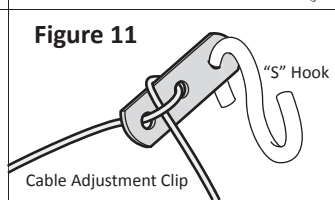
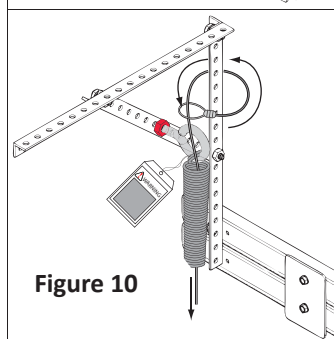
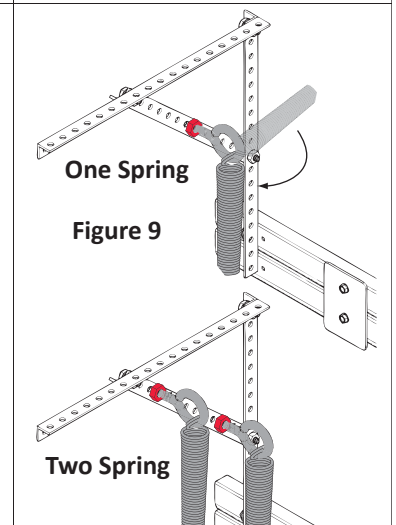
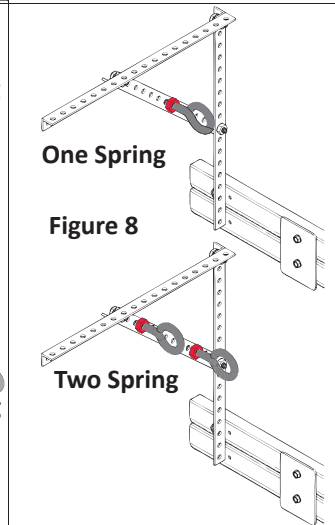
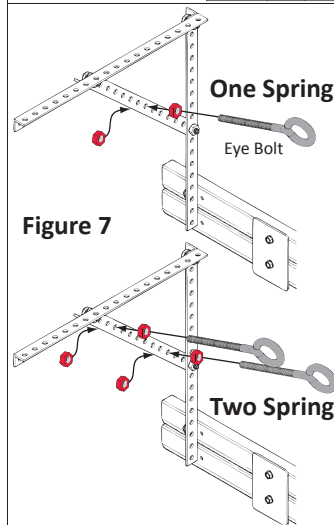
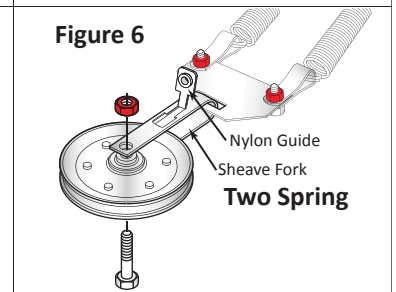
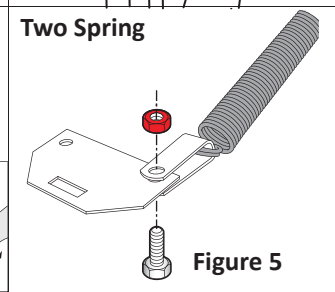
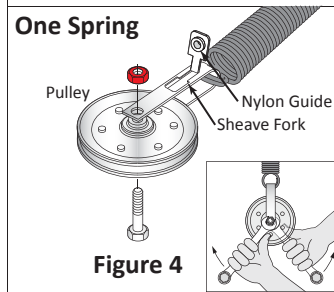
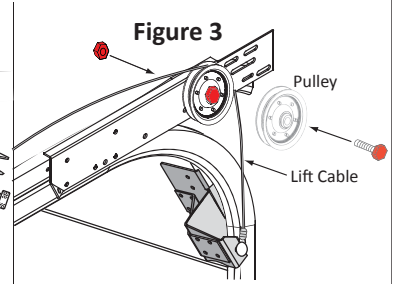
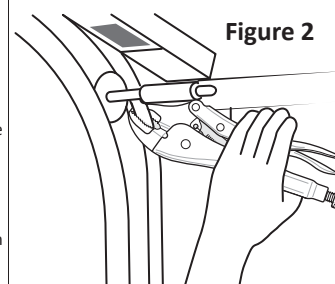
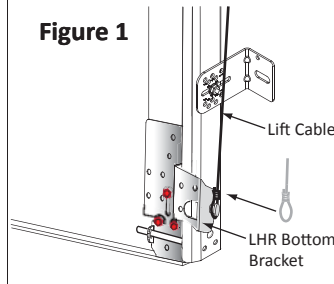

Extension Spring Low Head Room

Amarr

ENTRE//MATIC

Since 1951, we have successfully raised the standards of quality, value, and dependability in our industry. Today, with the same promise of individual attention and great value for all our customers, we remain committed to offering products and services that raise those standards even higher.

165 Carriage Court
Winston-Salem, NC 27105
800.503.DOOR
www.amarr.com



Entrematic reserves the right to change specifications and designs without notice and without incurring obligations.

Sectional door products from Entrematic may be the subject of one or more U.S. and/or foreign, issued and/or pending, design and/or utility patents.

Amarr, Classica, Stratford and Oak Summit as word and logos are registered trademarks belonging to Entrematic Group AB or other companies controlled by the same organizations. All rights reserved.

©Entrematic Group AB 2014. All rights reserved

Visit amarr.com for additional information on Amarr garage doors, garage door openers and garage door accessories.

Amarr
ENTRE//MATIC